

SWING R2

DE: Montageanleitung

CZ: Návod k montáži

ES: instrucciones de montaje

GB: Assembly instructions

NL: Montagehandleiding

FR: Notice de montage

PL: Instrukcja montażu

SK: Návod na montáž

RO: Instrucțiuni de montaj

SE: Monteringsanvisningar

UA: Керівництво з монтажу

GR: Οδηγίες συναρμολόγησης

SI: Navodila za montažo

HR: Upute za montažu

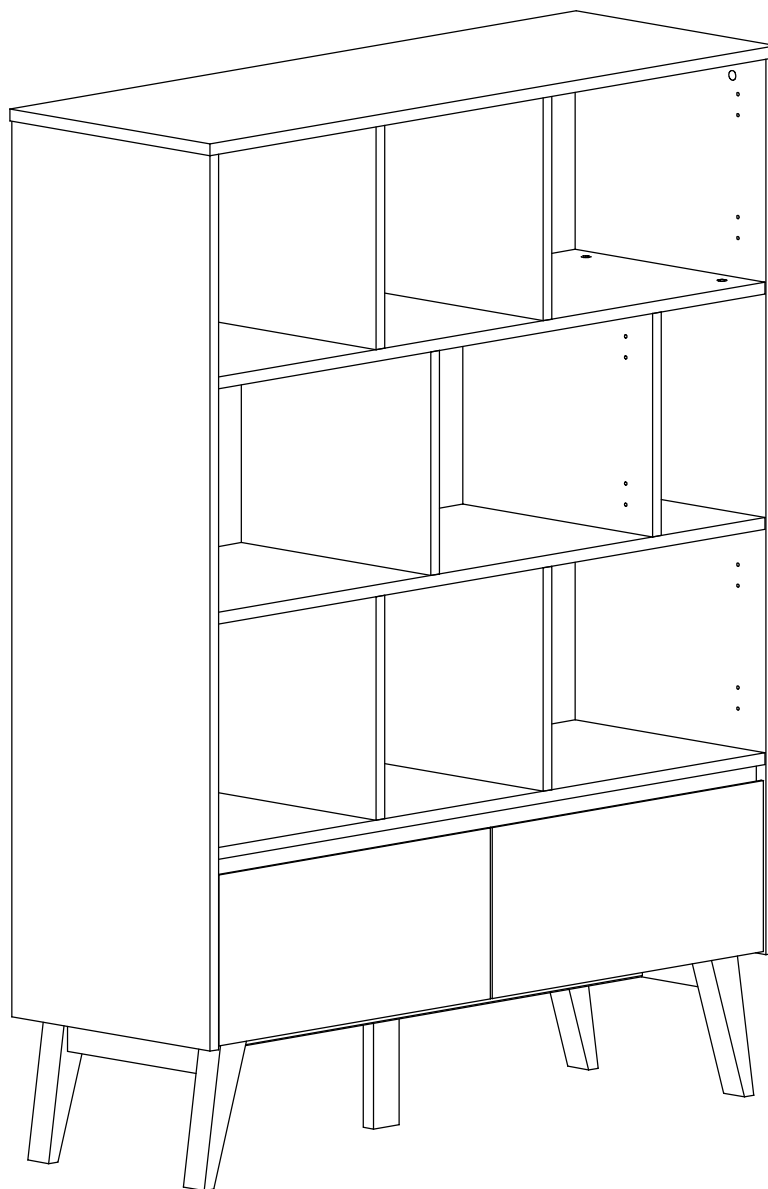

Narzędzia
Tools required
Outillage nécessaire
Werkzeuge
Delovno orodje
Alat

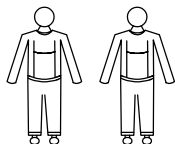
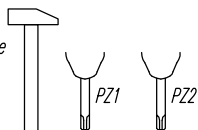

Ostrzeżenie! Nie pozostawiać dzieci bez opieki w pobliżu mebli podczas montażu. Małe części, niebezpieczeństwo uduszenia.

Warning! Do not leave children unattended near furniture during installation. Small parts, the danger of suffocation.

Achtung! Lassen Sie Kinder nicht unbeaufsichtigt in der Nähe von Möbel während der Installation. Kleine Teile, die Gefahr des Erstickens.

Attention! Ne laissez pas les enfants sans surveillance à proximité des meubles lors de leur montage. Les petites pièces peuvent présenter un risque de suffocation.

Opozorilo! Otroka ne puščajte brez nadzora staršev med montažo.

Upozorenje! Dijete ne puštajte bez nadzora roditelja tijekom montaže.

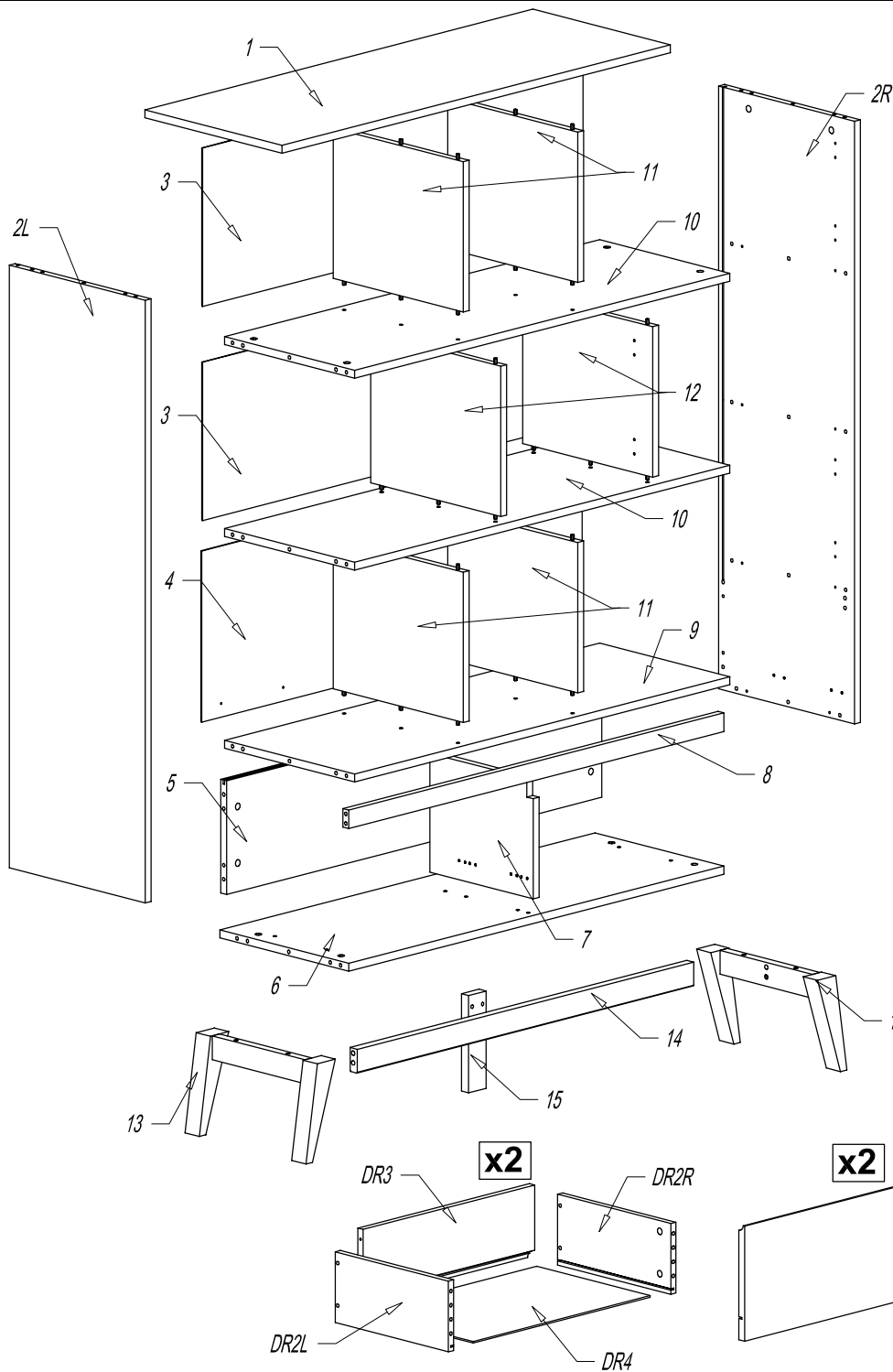

Colli 1/4:

- Nr 2L -x1
- Nr 2R -x1
- Nr 3 -x2
- Nr 4 -x1
- Nr 5 -x1
- Nr 8 -x1
- Nr 14 -x1

Colli 2/4:

- Nr 1 -x1
- Nr 6 -x1
- Nr 9 -x1
- Nr 10 -x2

Colli 3/4:

- Nr 7 -x1
- Nr 11 -x4
- Nr 12 -x2
- Nr 15 -x1
- Nr DR1-x2
- Nr DR2L -x2
- Nr DR2R -x2
- Nr DR3 -x2
- Nr DR4 -x2
- Nr AI -x1
- Nr FIT -x1

Colli 4/4:

- Nr 13 -x2

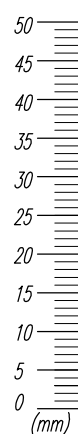
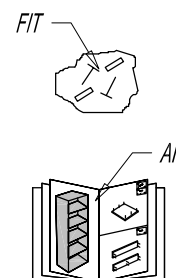

<p>A</p> <p>∅8x40 x50</p>	<p>B</p> <p>L34/St x32</p>	<p>C</p> <p>∅15/15 x32</p>	<p>D</p> <p>MAXI M6 x2</p>	<p>E</p> <p>MAXIFIX x2</p>	<p>F</p> <p>∅3x16 x4</p>	<p>G</p> <p>EURO ∅6x11 x16</p>
<p>H</p> <p>∅3.0x20 x18</p>	<p>J</p> <p>∅7x50 x10</p>	<p>K</p> <p>x12</p>	<p>L</p> <p>M6x35 x6</p>	<p>M</p> <p>∅17 biate x20</p>	<p>N</p> <p>x6</p>	<p>O</p> <p>x4</p>
<p>P</p> <p>∅4,0x16 x8</p>	<p>R</p> <p>L-40mm x5</p>	<p>S</p> <p>∅5 biate x20</p>	<p>SW6</p> <p>x1</p>	<p>ZR</p> <p>ZL</p>		
<p>SWING R2</p> <p>2/9</p>	<p>SW4</p> <p>x1</p>	<p>LOGO</p> <p>www.pinio.com.pl x1</p>	<p>x2</p>	<p>FAV-Q/L-350mm x2</p>		

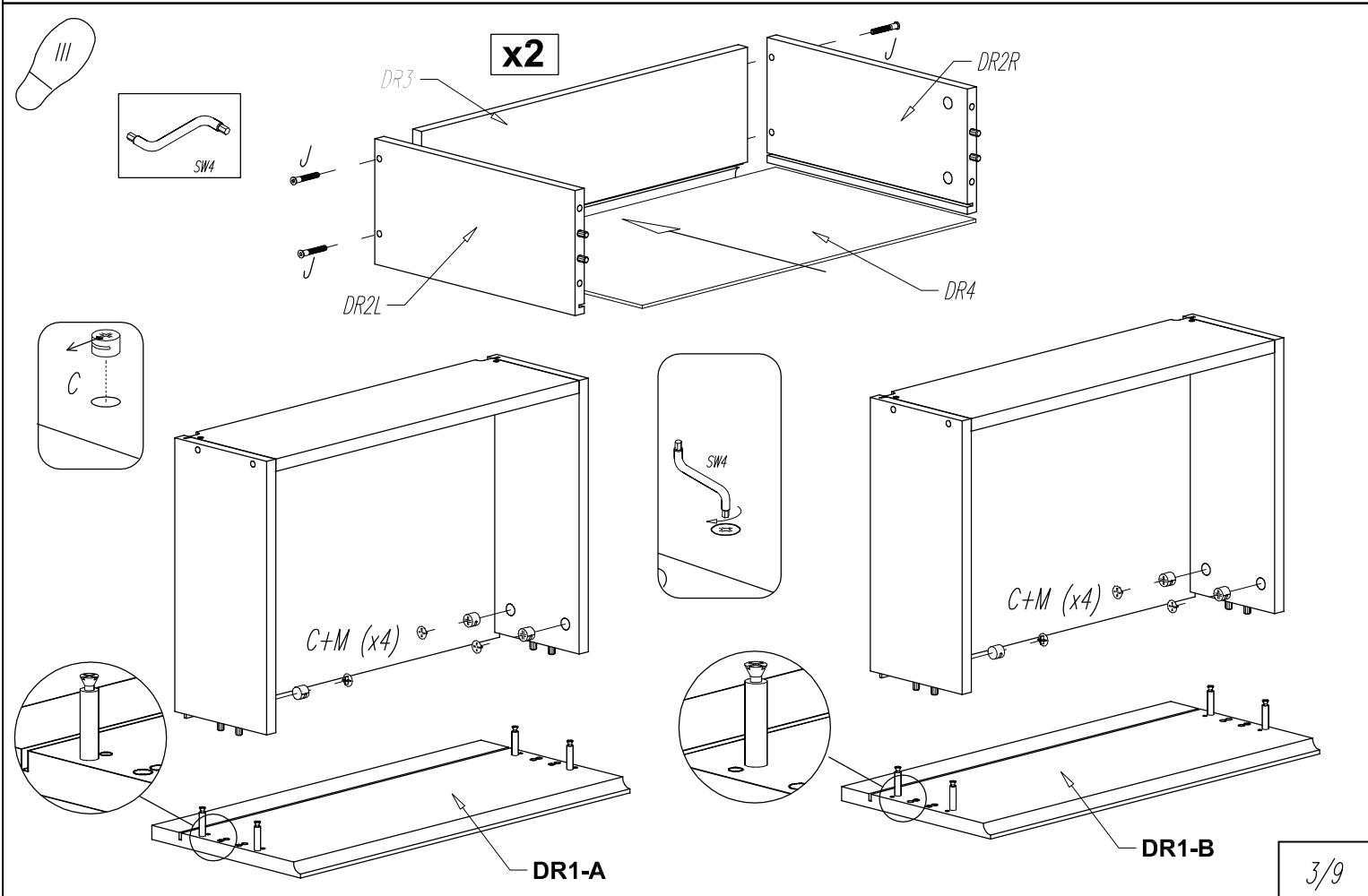
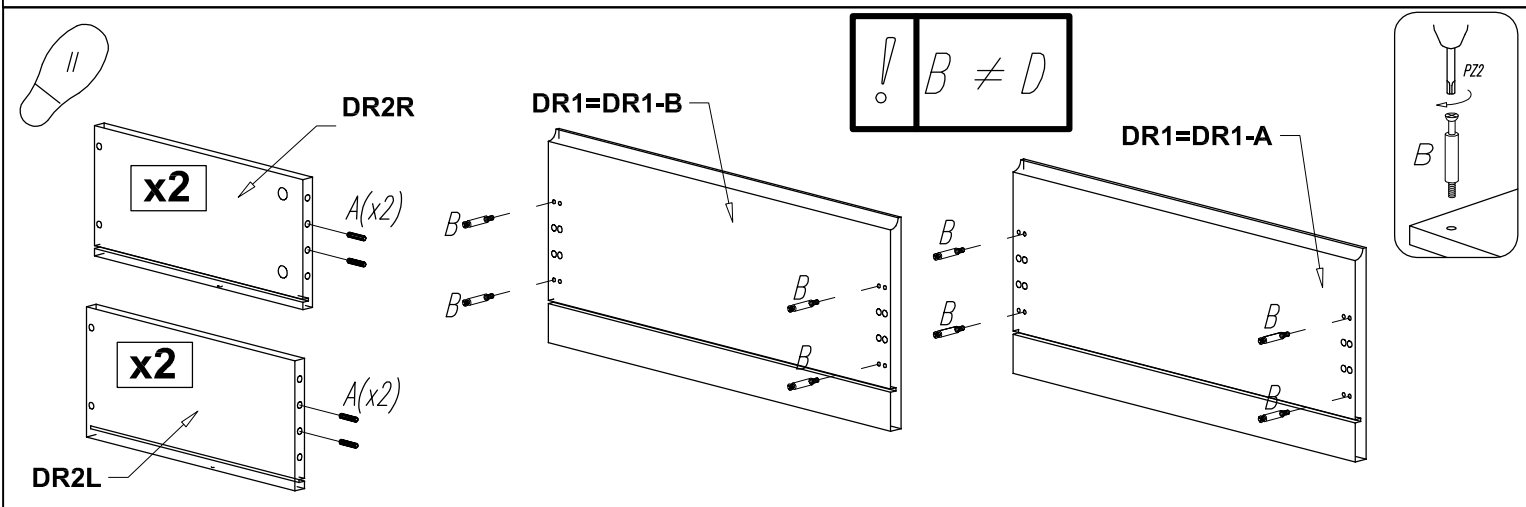
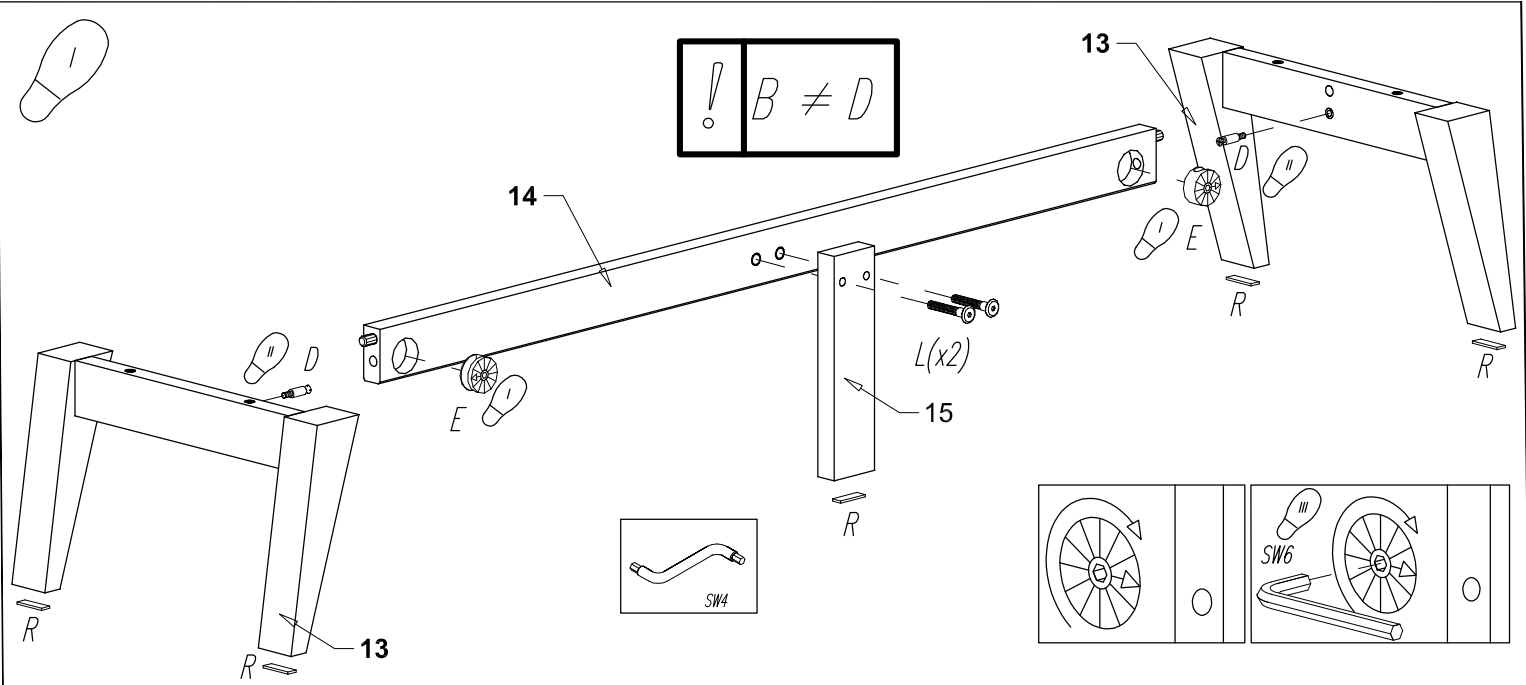

IV

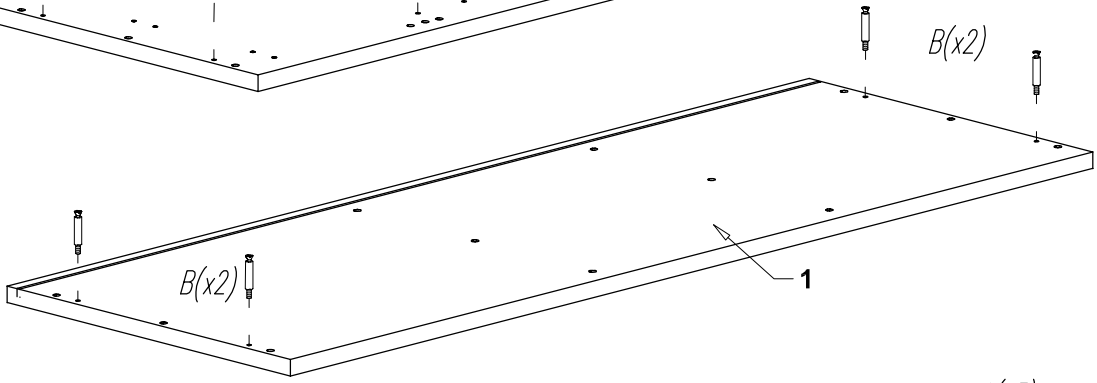
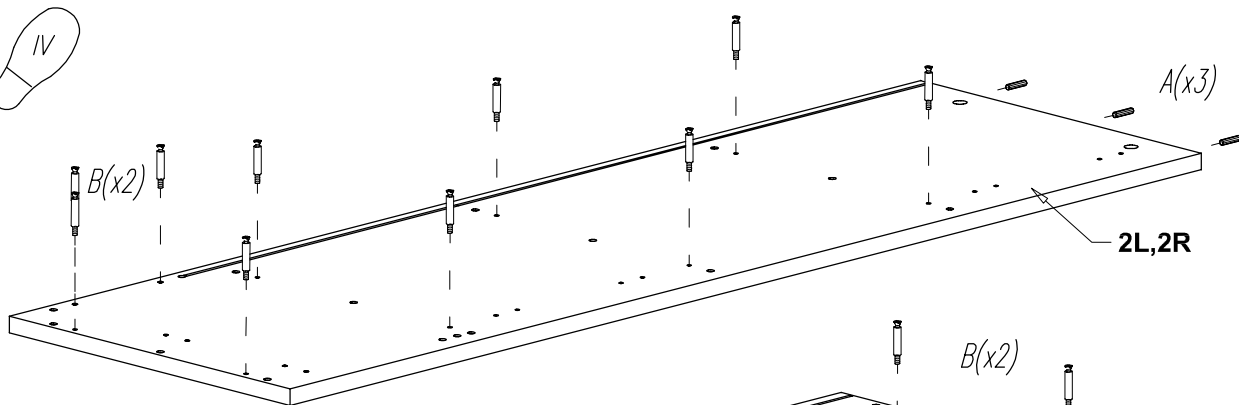

! $B \neq D$

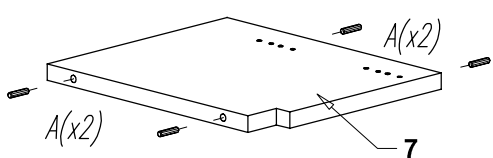
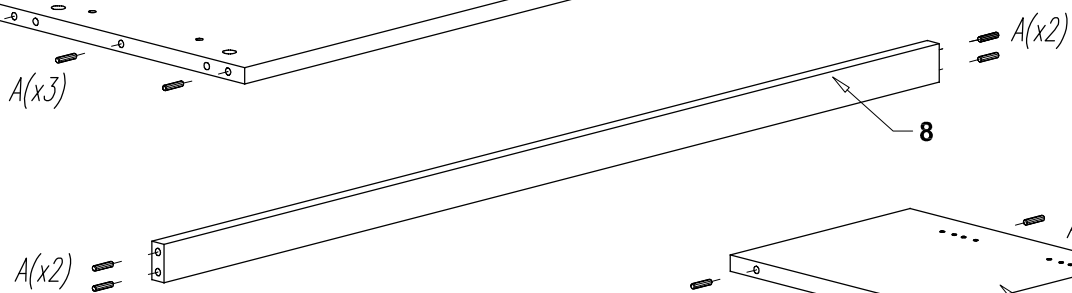
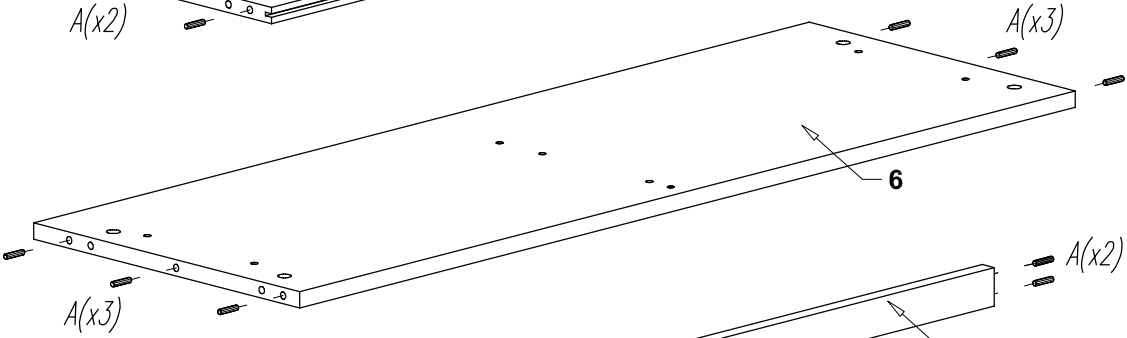
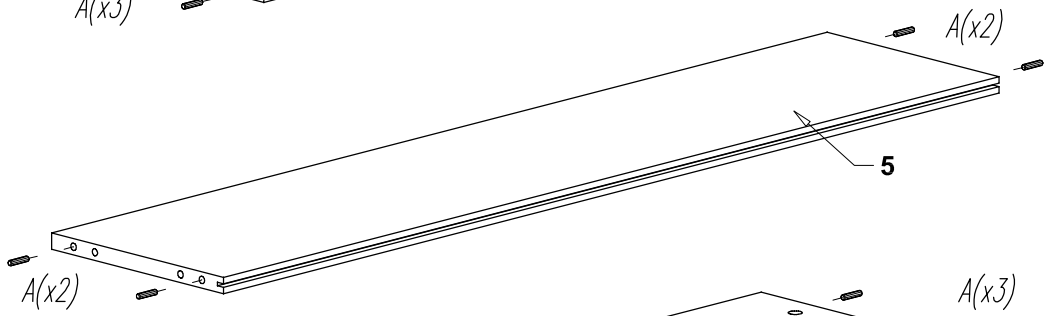
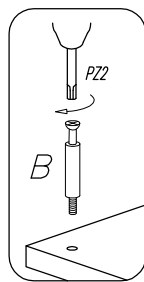
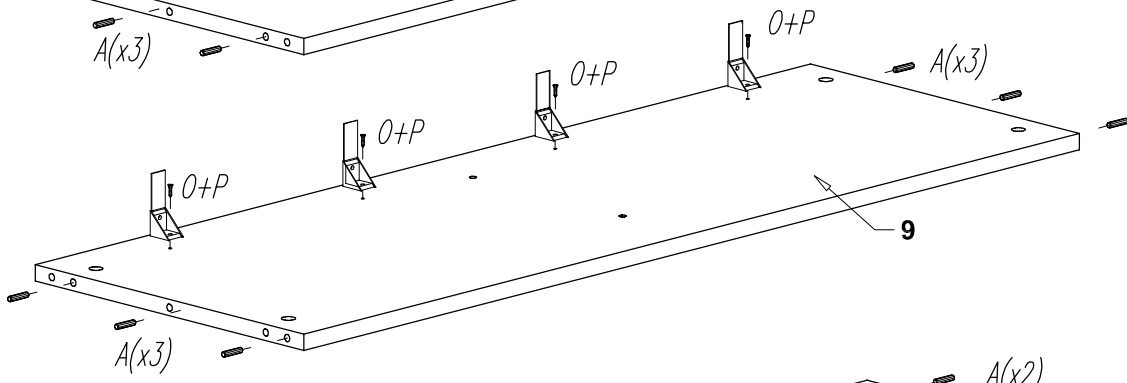
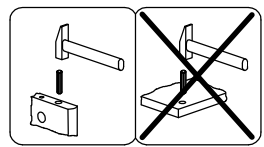
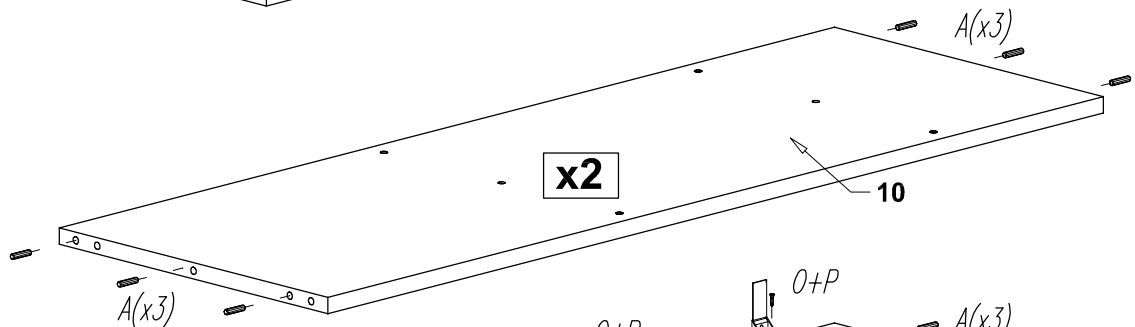

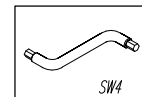
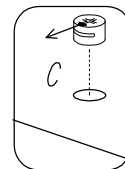
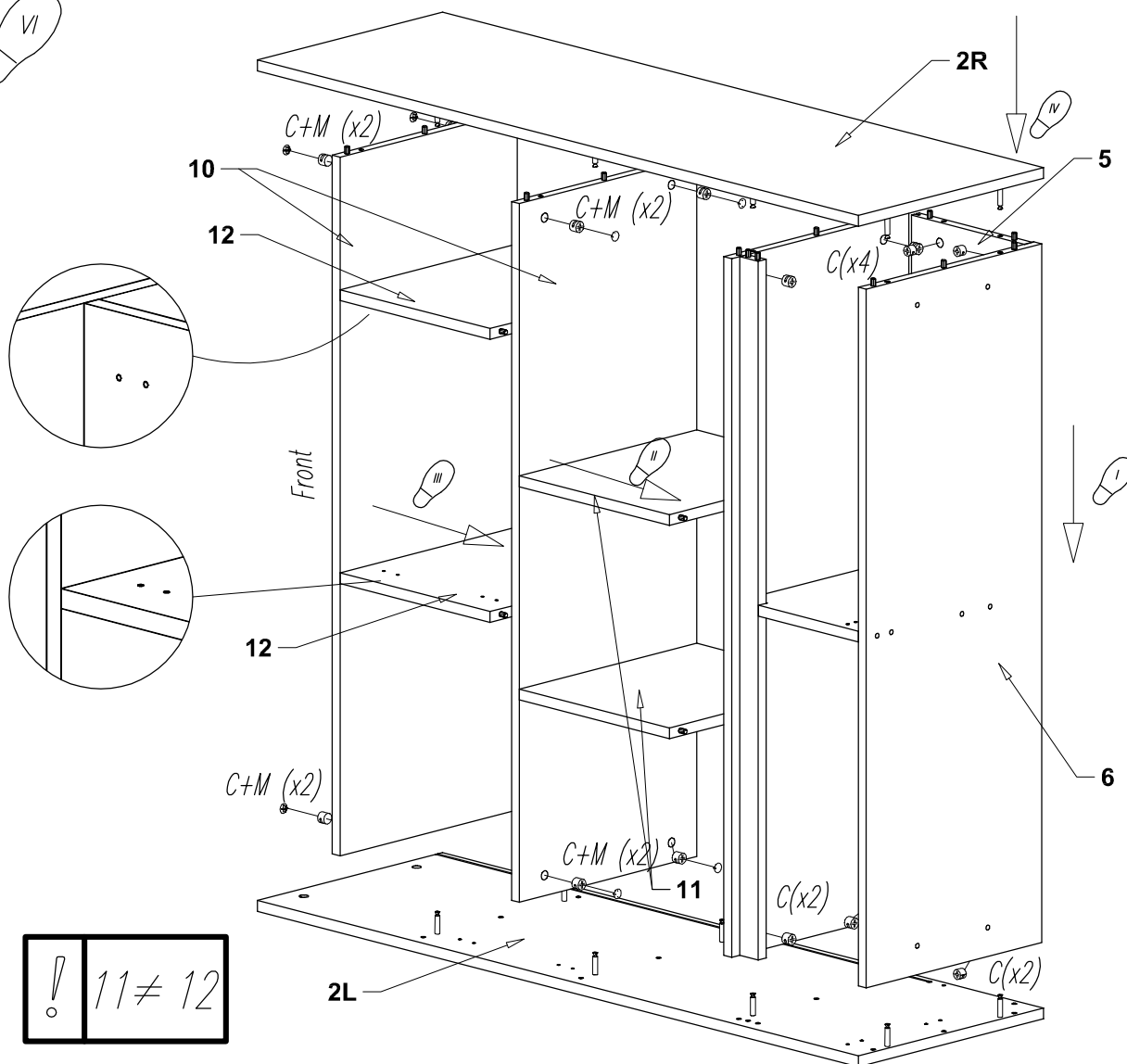
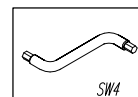
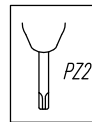
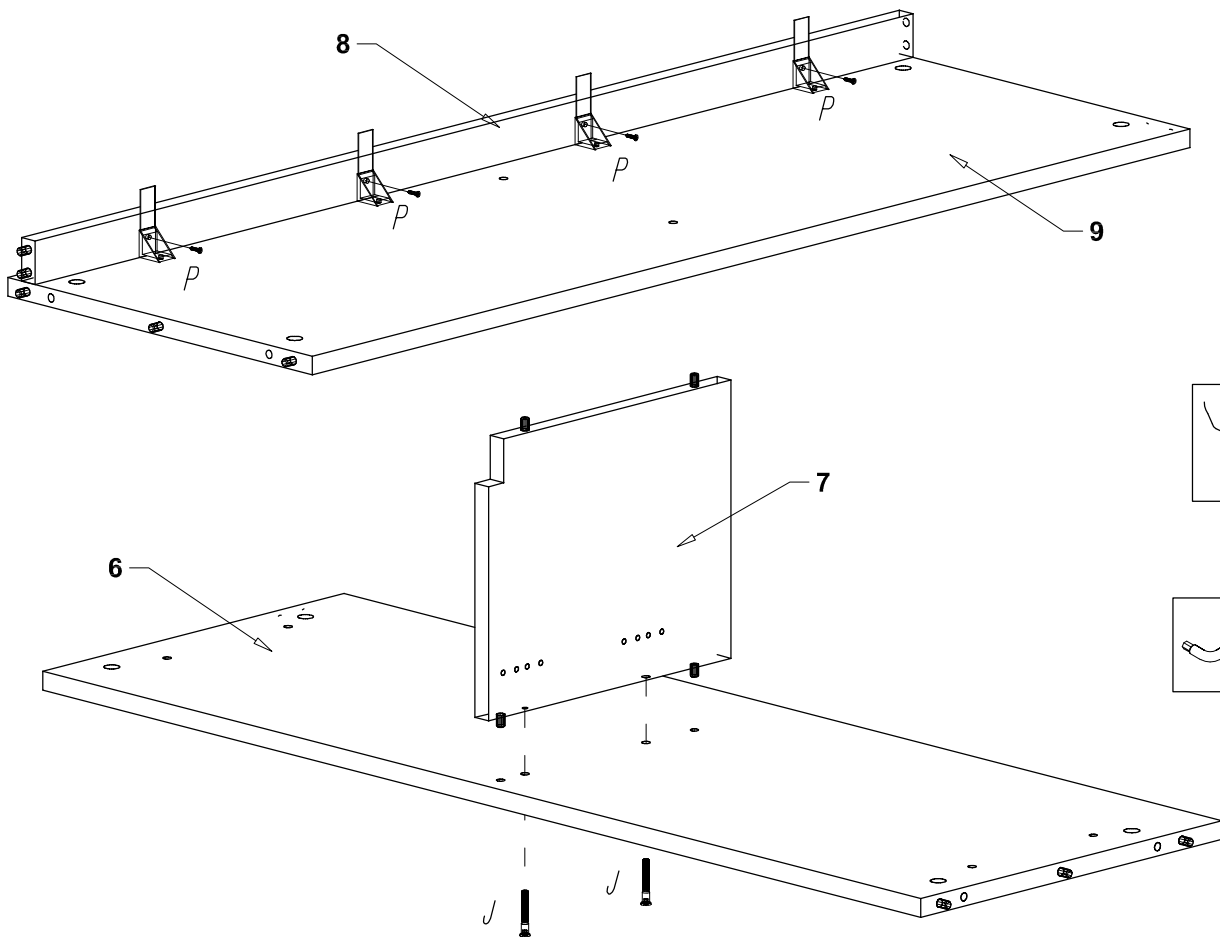

! 11 ≠ 12

VII

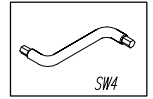
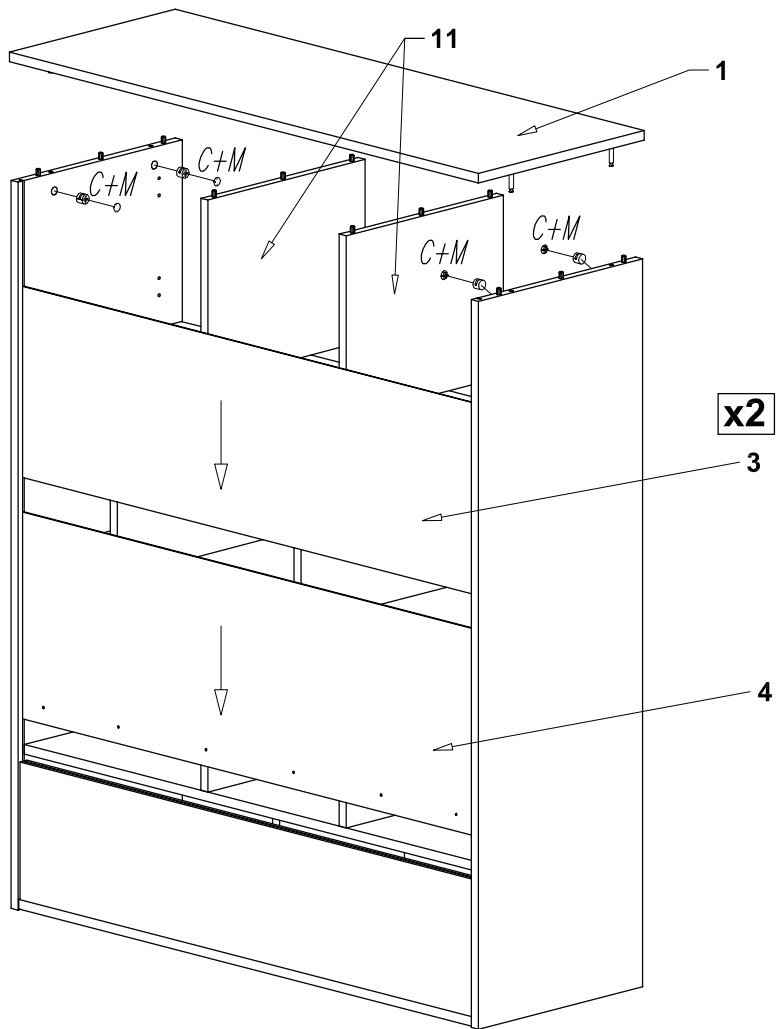
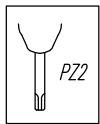

VIII

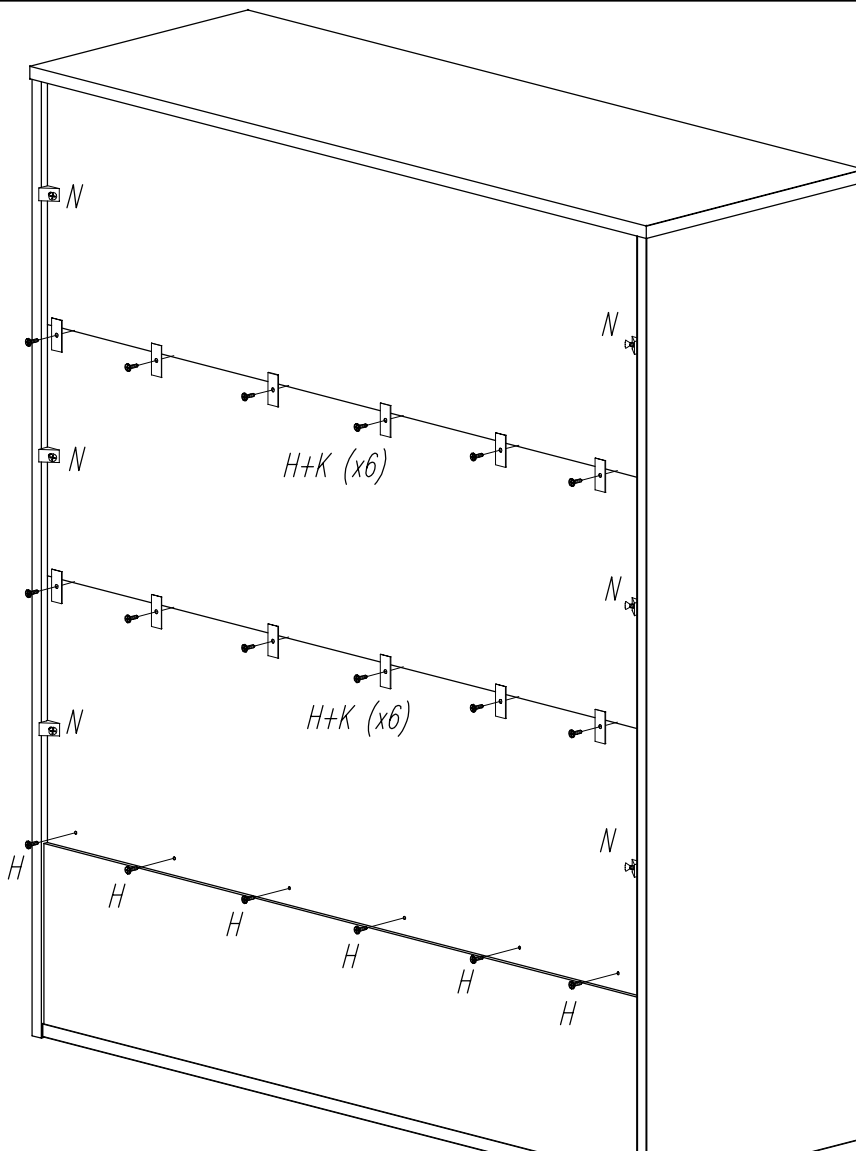
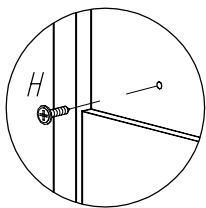
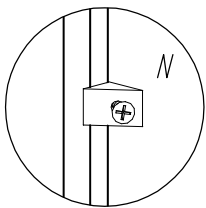
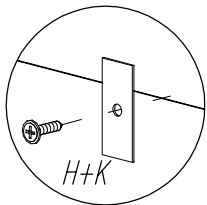

IX

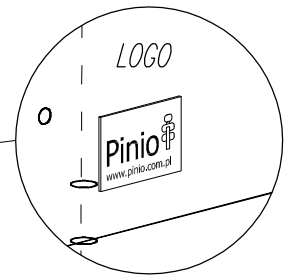
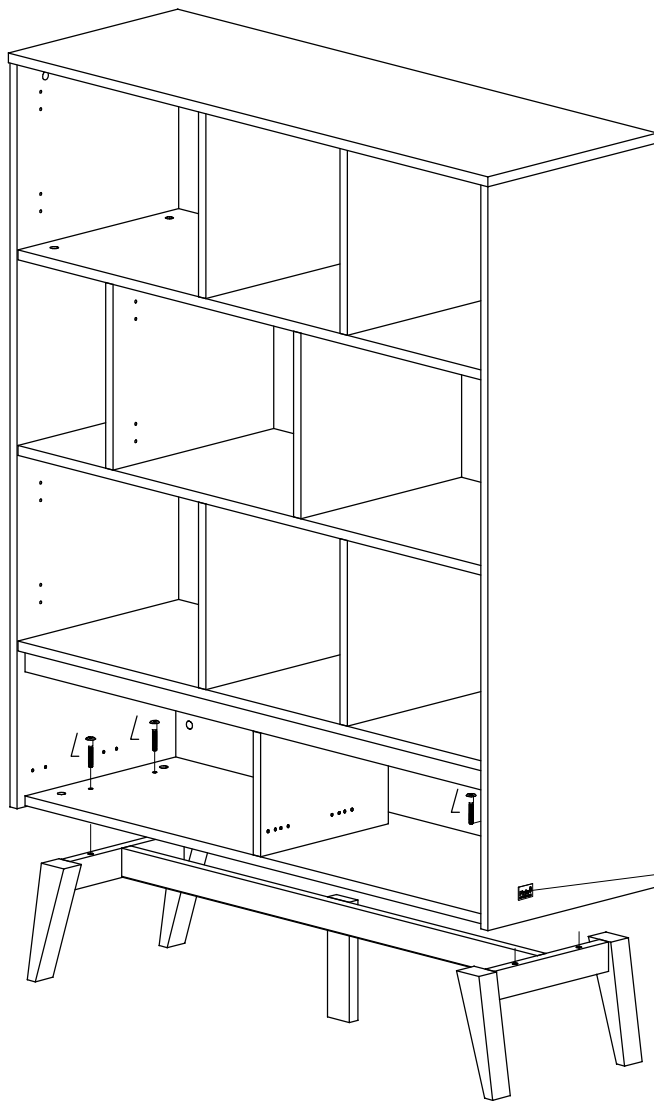
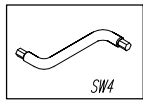

X

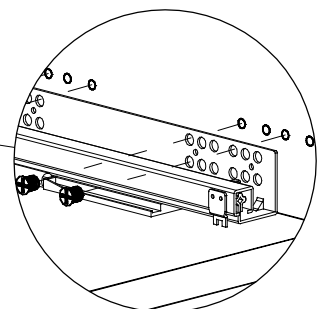
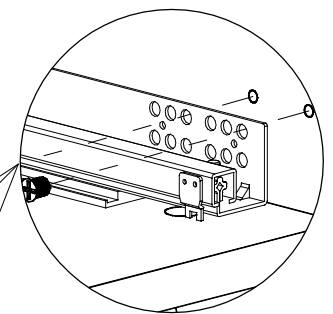
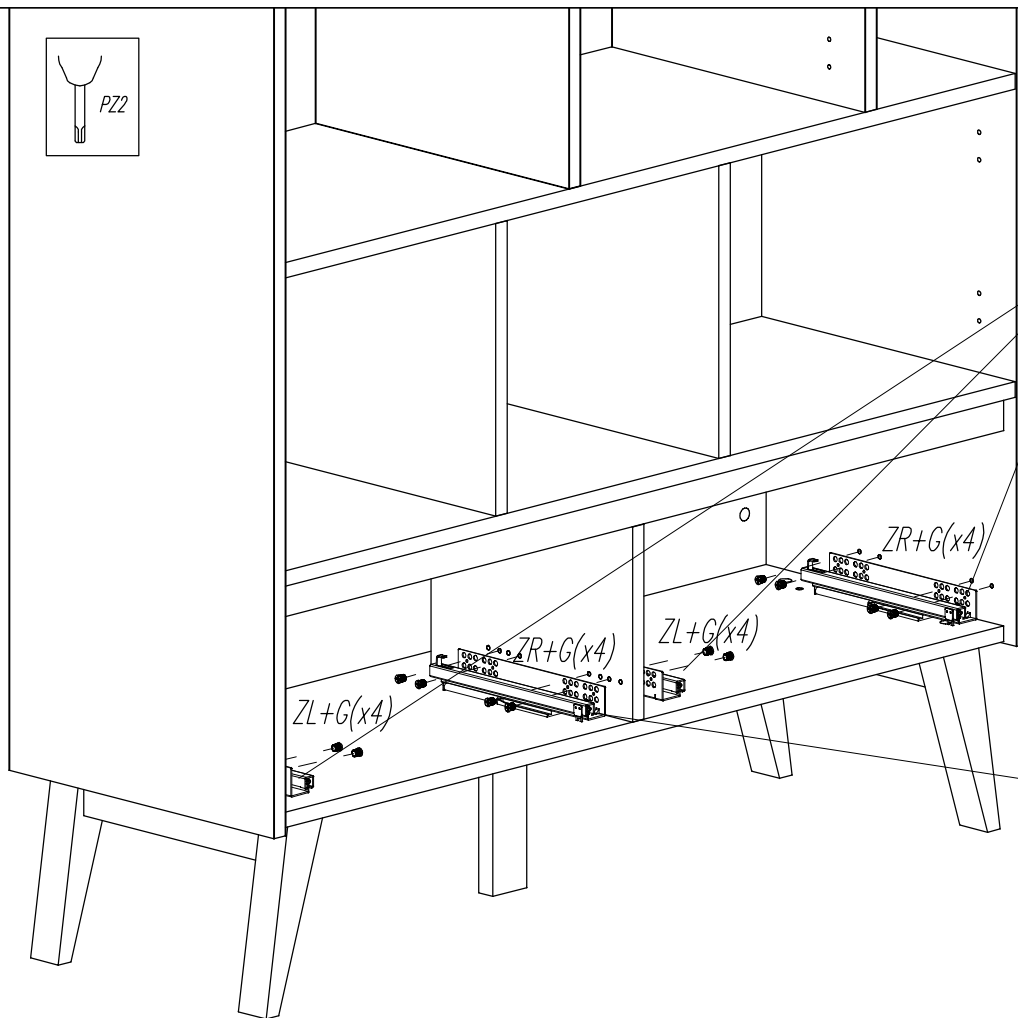
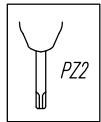

X1

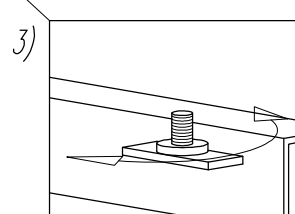
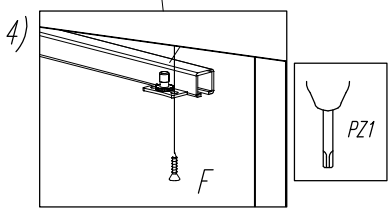
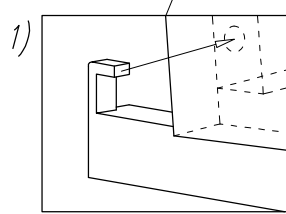
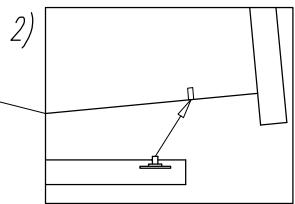
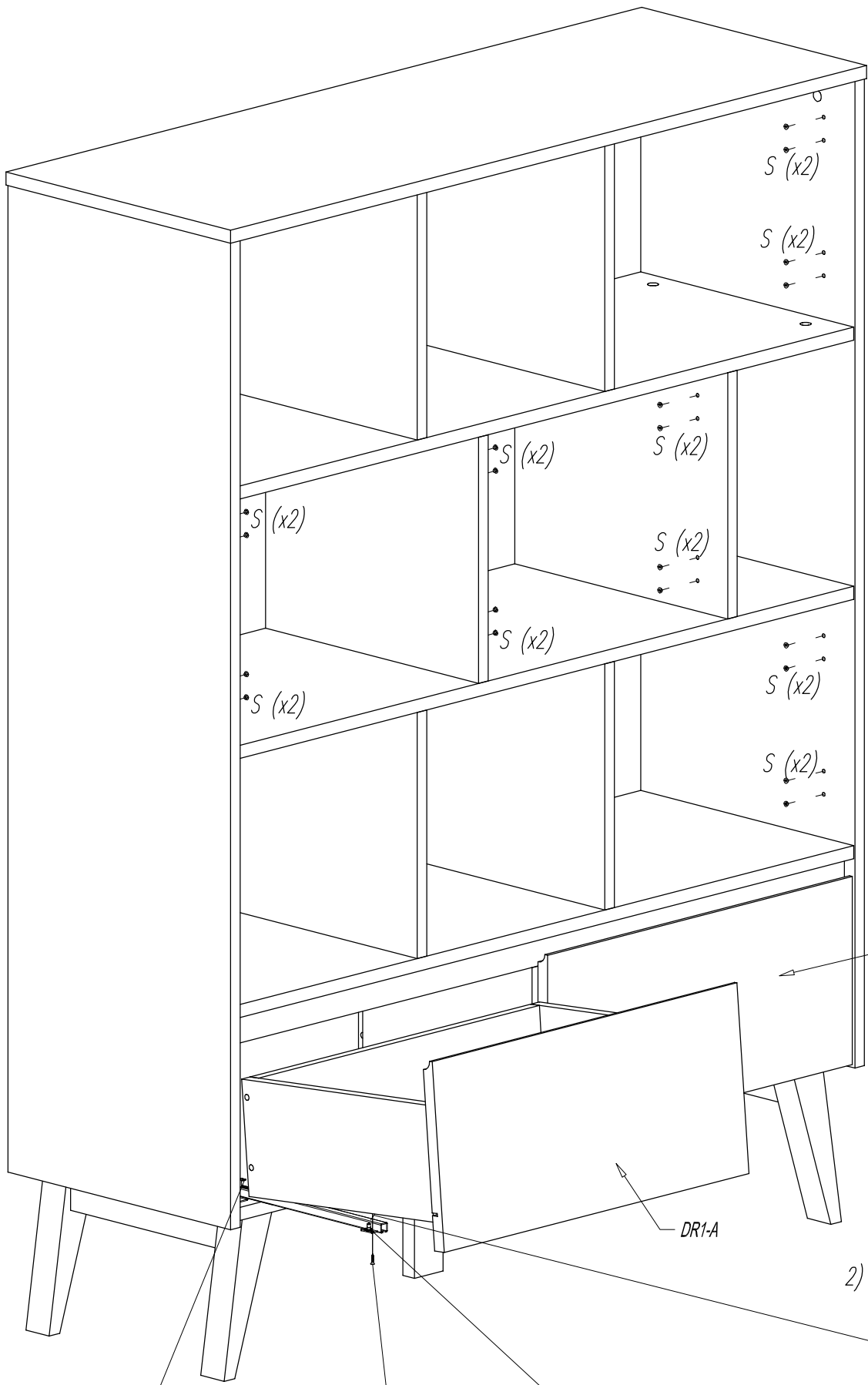



Zabezpieczenie przed przewracaniem

Kippsicherung

Prevention of tipping over

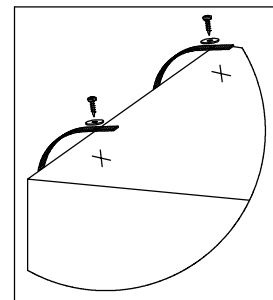
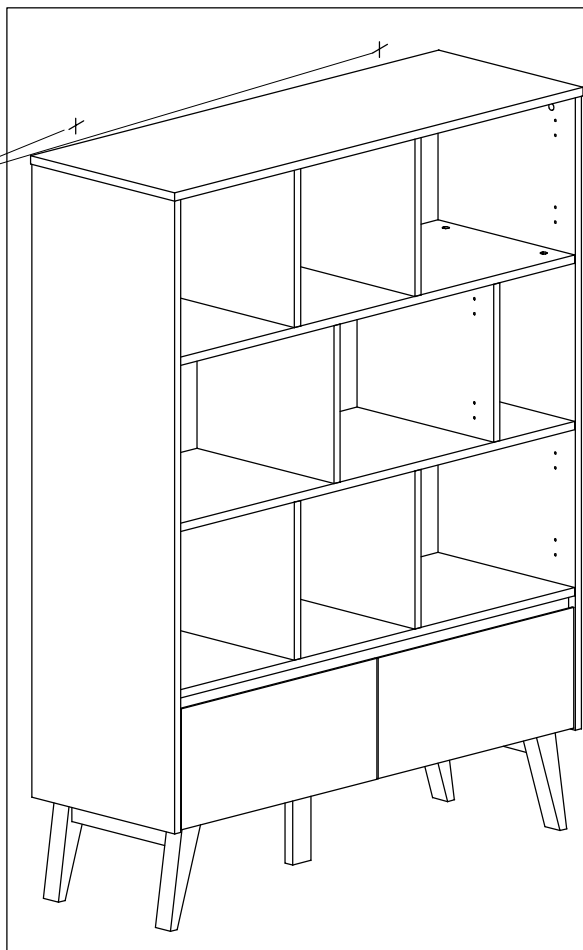
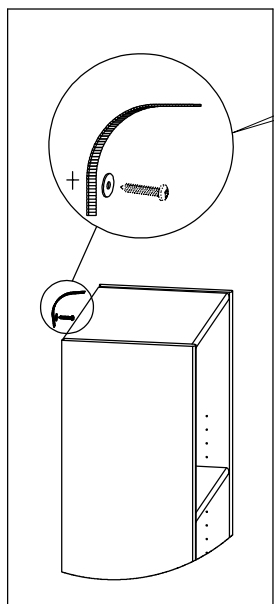
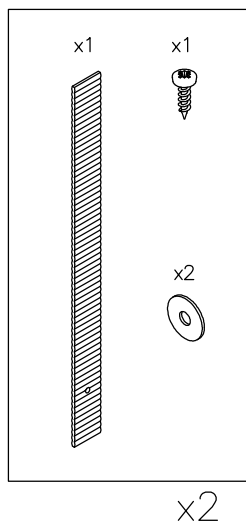
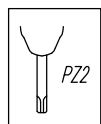

PL

Konieczny jest montaż do ściany.

Ponieważ materiał, z którego wykonano ścianę może być inny w każdym mieszkaniu, w komplecie nie znalazły się żadne umocowania ani wkręty. Aby uzyskać poradę w kwestii doboru odpowiednich wkrętów skontaktuj się z lokalnym sklepem specjalistycznym.

GB

Wall mounting is required.

As wall materials vary, screws for fixing to wall are not included. For advice on suitable screw systems, contact your local specialized dealer.

DE-AT

Wandmontage ist erforderlich.

Da es viele verschiedene Wandmaterialien gibt, sind Schrauben für die Wandbefestigung nicht beigelegt. Ggf. sollte man sich beim Eisenwarenfachhandel nach geeignetem Befestigungsmaterial erkundigen.

FR

Un montage mural est indispensable.

Les vis et ferrures pour fixer le meuble/l'objet au mur ou au plafond ne sont pas incluses. Choisissez des vis et ferrures adaptées au matériau de votre mur. En cas de doute, demandez conseil à un vendeur spécialisé.

SI:

Potrebna montaža na steno.

Ker se stenski materiali razlikujejo, vijaki za pritrditev na steno niso vključeni. Za nasvete o primernih vijačnih sistemih se obrnite na lokalnega specializiranega prodajalca.

HR:

Potrebna je ugradnja na zid.

Budući da postoje različiti materijali od kojih su zidovi izrađeni, vijci za zidnu montažu nisu uključeni. Za savjet o odgovarajućim vijcima se obratite specijaliziranom prodavaču.