

SWING

DE: Montageanleitung

CZ: Návod k montáži

ES: instrucciones de montaje

GB: Assembly instructions

NL: Montagehandleiding

FR: Notice de montage

PL: Instrukcja montażu

SK: Návod na montáž

RO: Instrucțiuni de montaj

SE: Monteringsanvisningar

UA: Керівництво з монтажу

GR: Οδηγίες συναρμολόγησης

SI: Navodila za montažo

HR: Upute za montažu

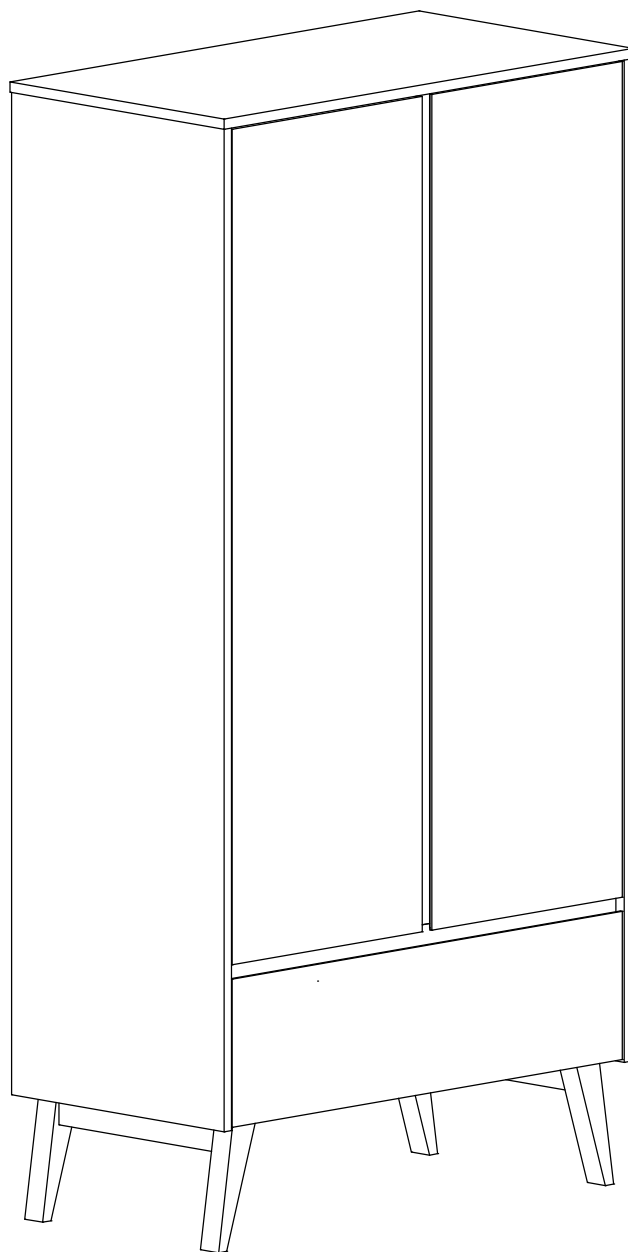

Narzędzia
Tools required
Outils nécessaires
Werkzeuge
Delovno orodje
Alat

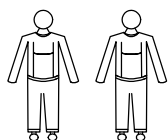
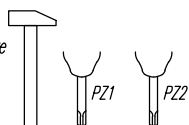

Ostrzeżenie! Nie pozostawiać dzieci bez opieki w pobliżu mebli podczas montażu. Małe części, niebezpieczeństwo uduszenia.

Warning! Do not leave children unattended near furniture during installation. Small parts, the danger of suffocation.

Achtung! Lassen Sie Kinder nicht unbeaufsichtigt in der Nähe von Möbel während der Installation. Kleine Teile, die Gefahr des Erstickens.

Attention! Ne laissez pas les enfants sans surveillance à proximité des meubles lors de leur montage. Les petites pièces peuvent présenter un risque de suffocation.

Opozorilo! Otroka ne puščajte brez nadzora staršev med montažo.

Upozorenje! Dijete ne puštajte bez nadzora roditelja tijekom montaže.

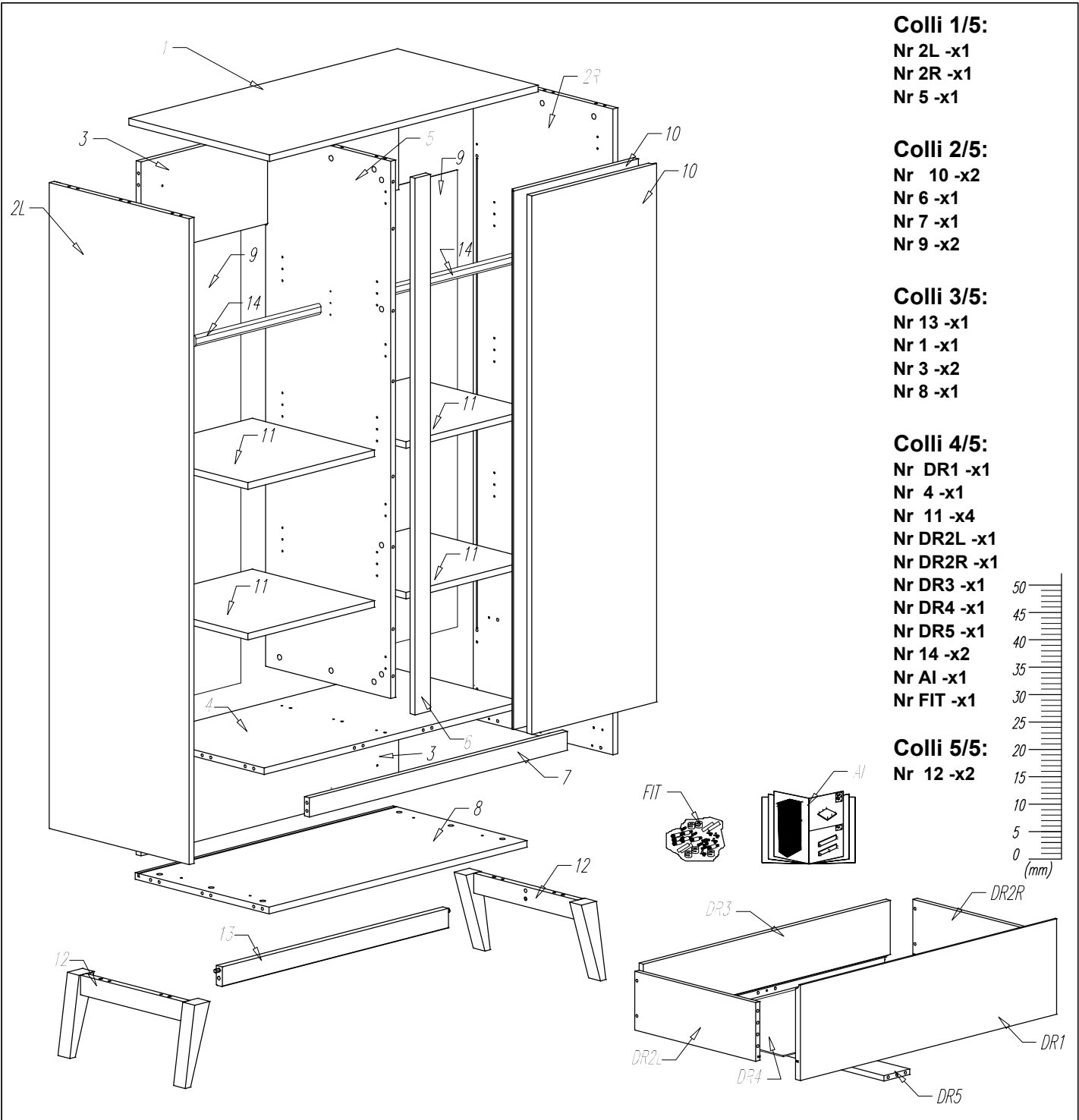

Colli 1/5:

- Nr 2L -x1
- Nr 2R -x1
- Nr 5 -x1

Colli 2/5:

- Nr 10 -x2
- Nr 6 -x1
- Nr 7 -x1
- Nr 9 -x2

Colli 3/5:

- Nr 13 -x1
- Nr 1 -x1
- Nr 3 -x2
- Nr 8 -x1

Colli 4/5:

- Nr DR1 -x1
- Nr 4 -x1
- Nr 11 -x4
- Nr DR2L -x1
- Nr DR2R -x1
- Nr DR3 -x1
- Nr DR4 -x1
- Nr DR5 -x1
- Nr 14 -x2
- Nr AI -x1
- Nr FIT -x1

Colli 5/5:

- Nr 12 -x2

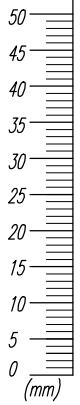

<p>A1</p> <p>∅8x40 x50</p>	<p>A2</p> <p>∅8x32 x4</p>	<p>B</p> <p>L34/St x43</p>	<p>C</p> <p>∅15/16 x43</p>	<p>D</p> <p>M6x35 x4</p>	<p>E</p> <p>x16</p>	<p>F</p> <p>Metal H x4</p>
<p>G</p> <p>EURO ∅6x11 x8</p>	<p>H</p> <p>MAXI M6 x2</p>	<p>K</p> <p>MAXI FIX x2</p>	<p>L</p> <p>∅4,0x45 x2</p>	<p>M</p> <p>∅7x50 x4</p>	<p>N</p> <p>∅3,5x20 x8</p>	<p>P</p> <p>x4</p>
<p>X1</p> <p>Met+/WP x8</p>	<p>X2</p> <p>Met+/H2 x8</p>	<p>X3</p> <p>∅4,0x16 x16+8</p>	<p>R</p> <p>∅17 biale x20</p>	<p>S</p> <p>x6</p>	<p>T</p> <p>L-40mm x4</p>	<p>SW6</p> <p>x1</p>
<p>2/11 SWING W2</p>		<p>LOGO</p> <p>x1</p>	<p>x2</p>	<p>ZL</p>	<p>ZR</p>	<p>FAV-Q/L-450mm x1</p>

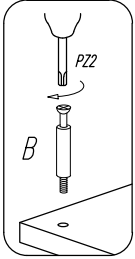
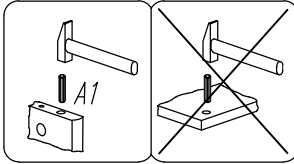
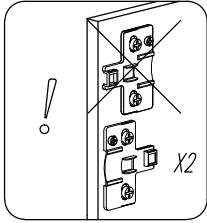

2L/2R

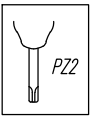

! $B \neq H$

! $A1 \neq A2$

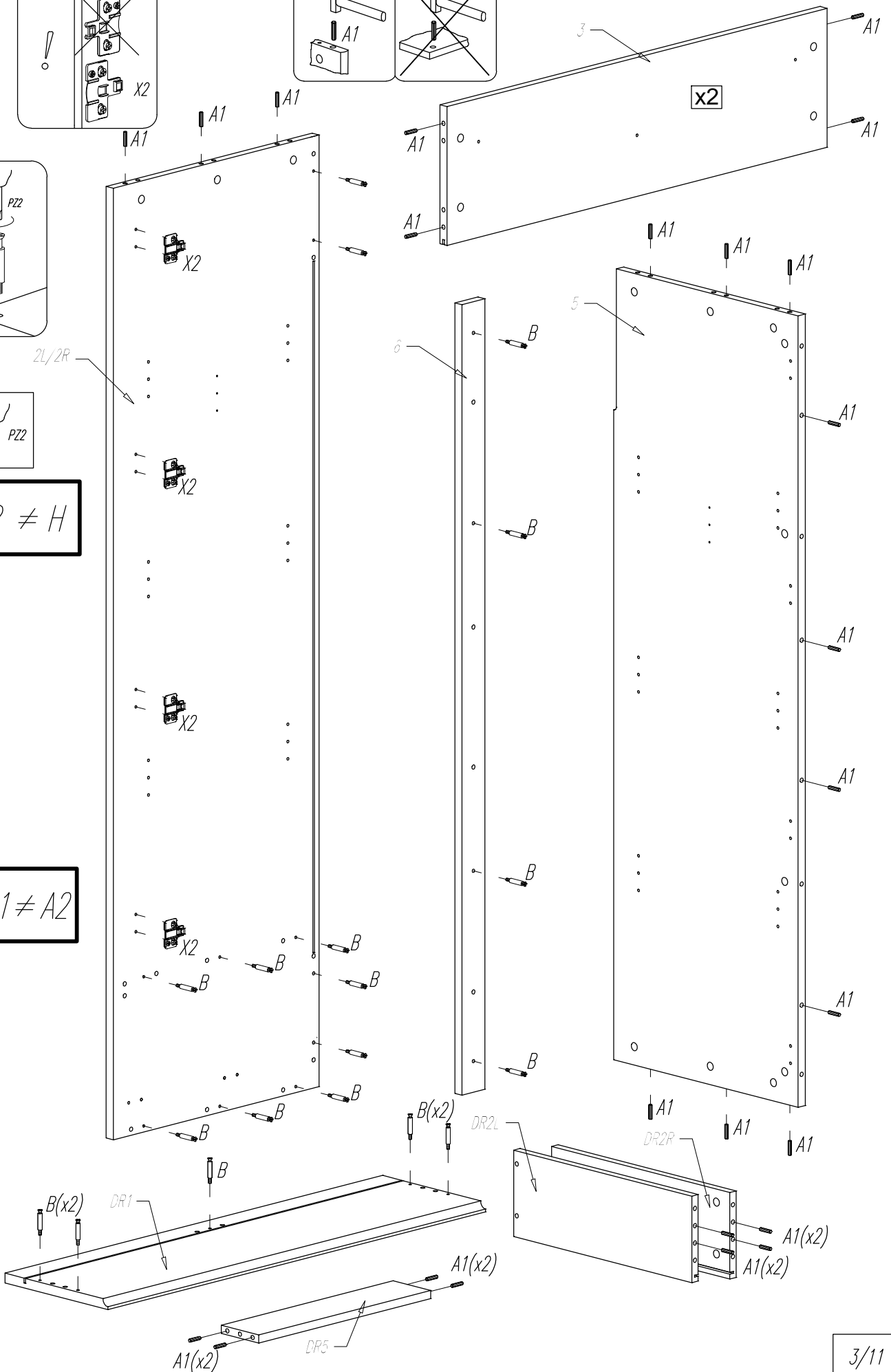

II

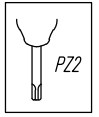
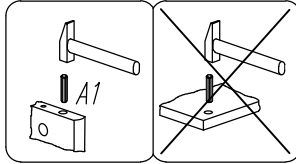
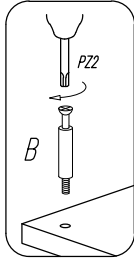

! $B \neq H$

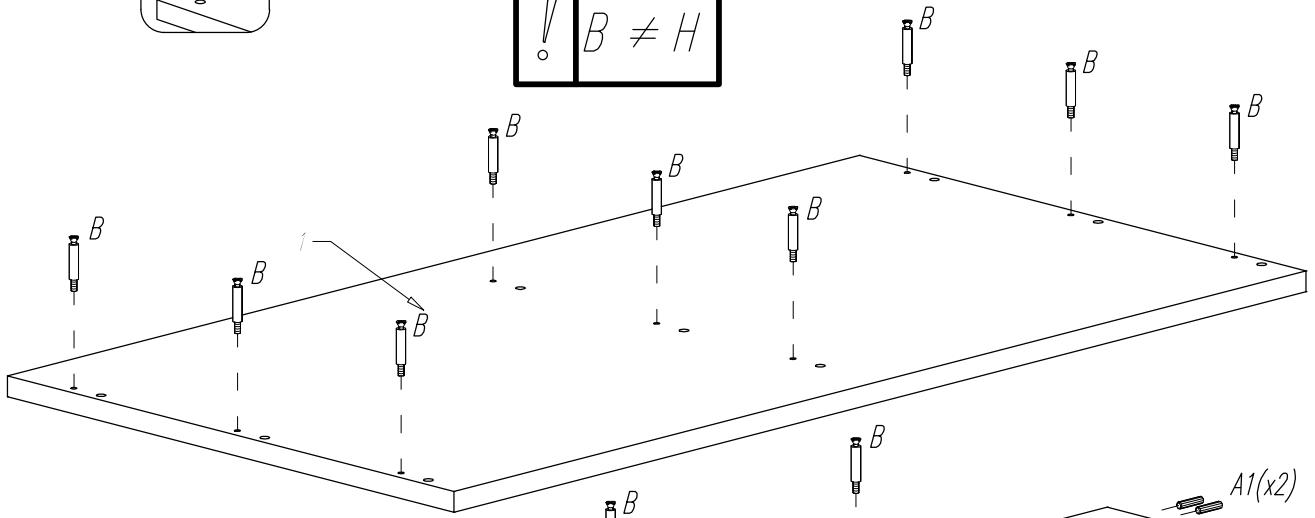

! $A1 \neq A2$

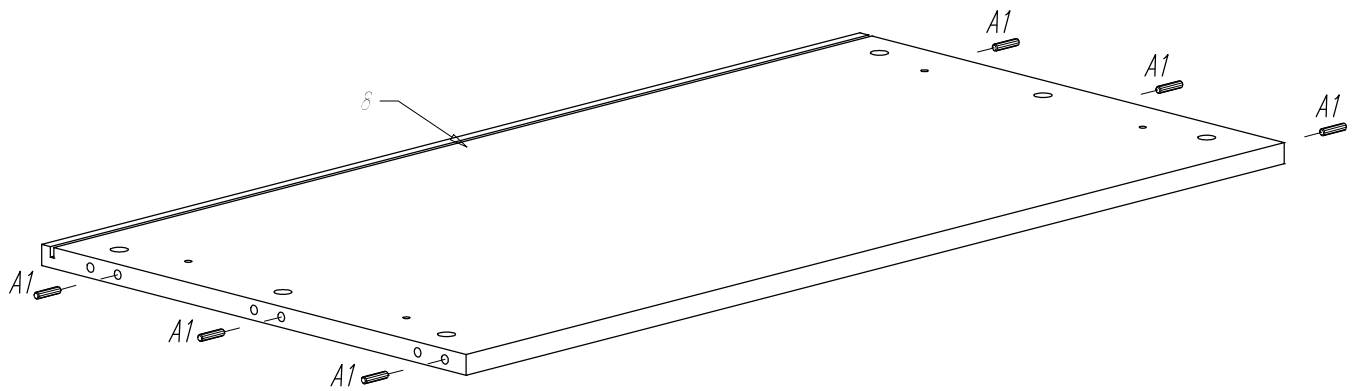
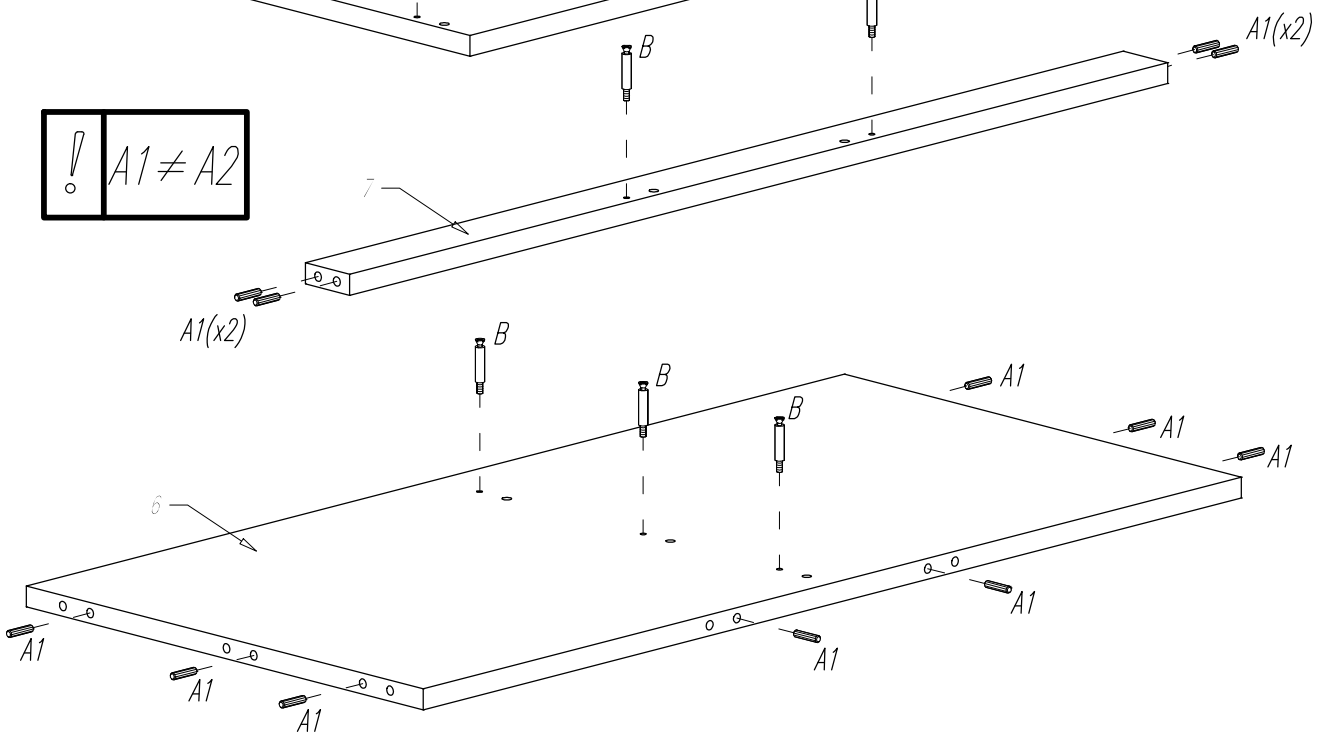

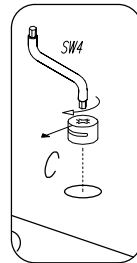
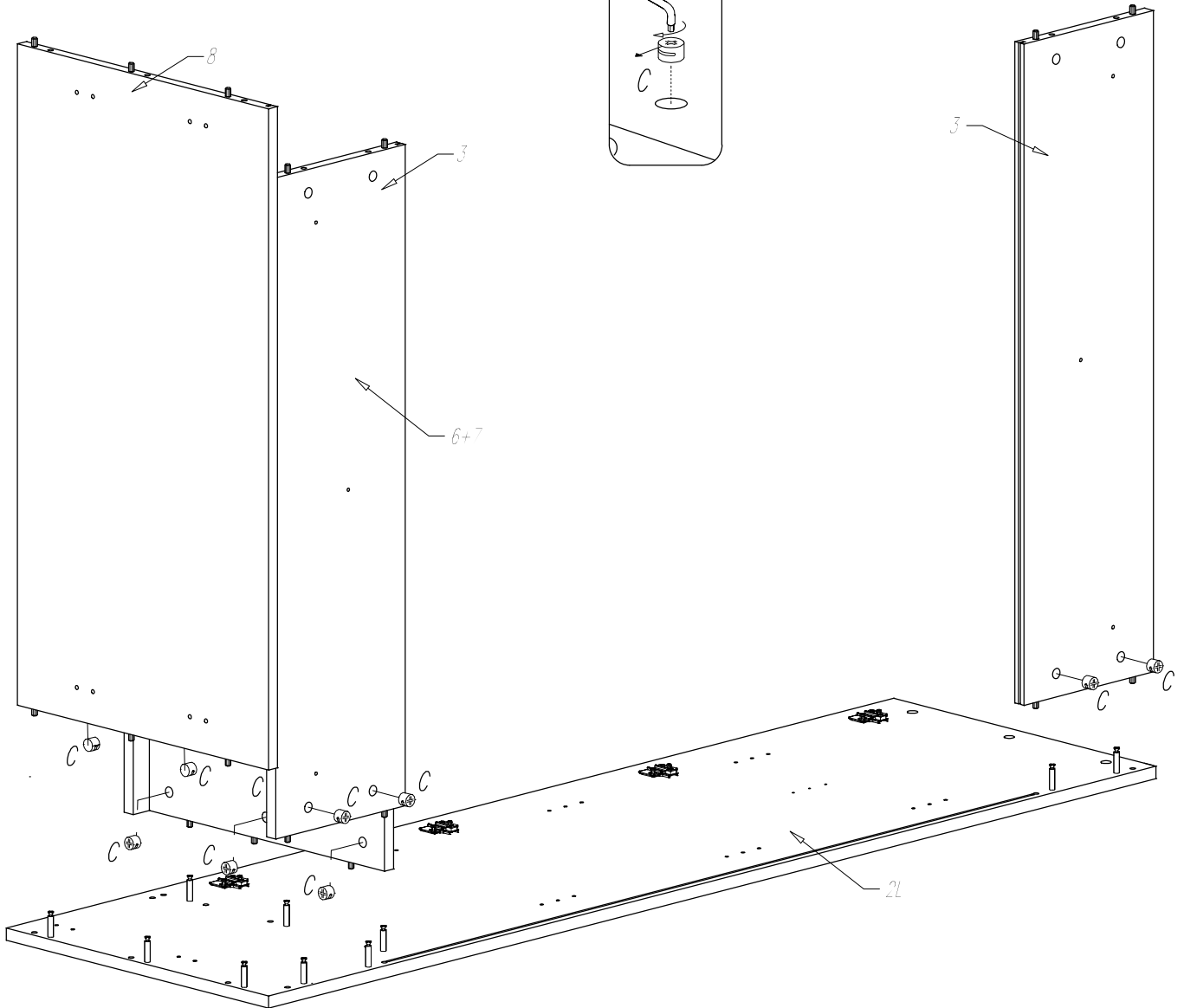
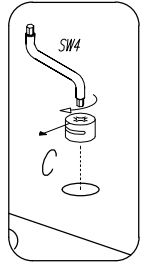
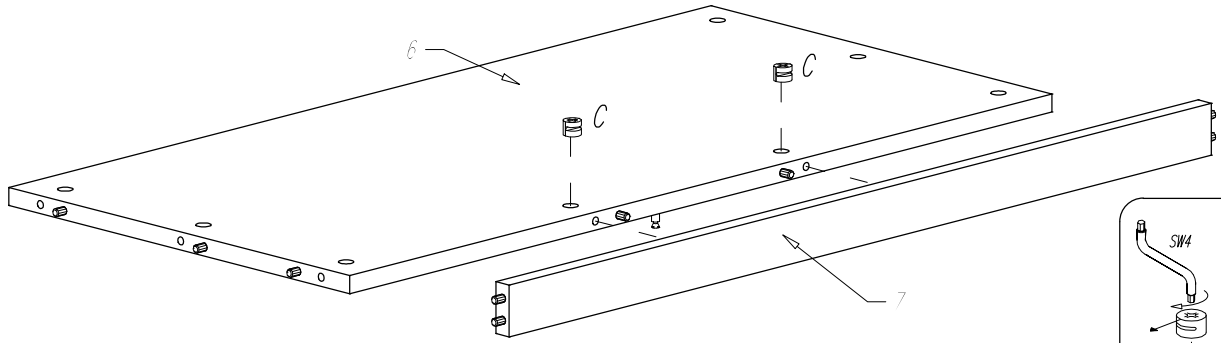

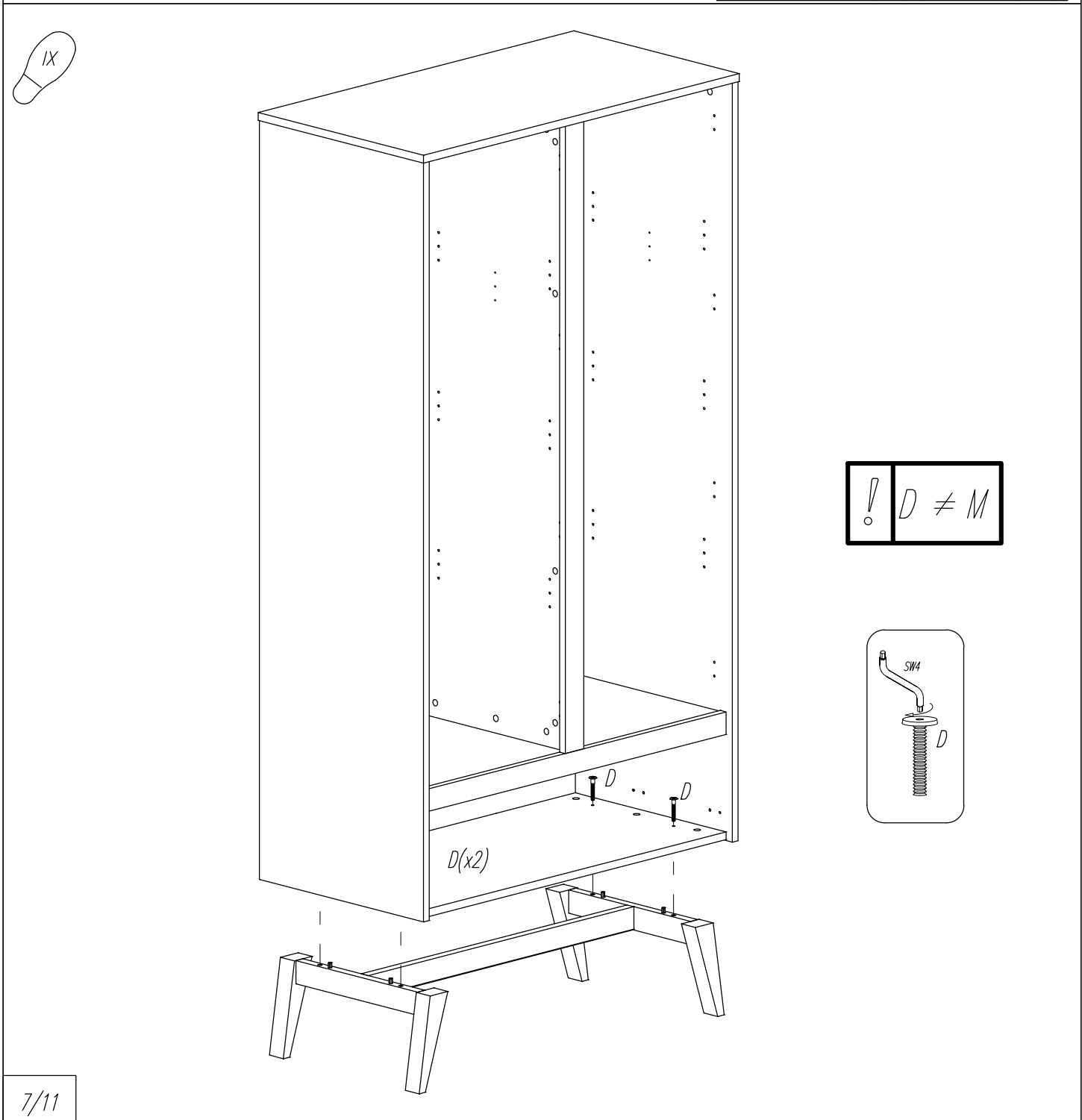
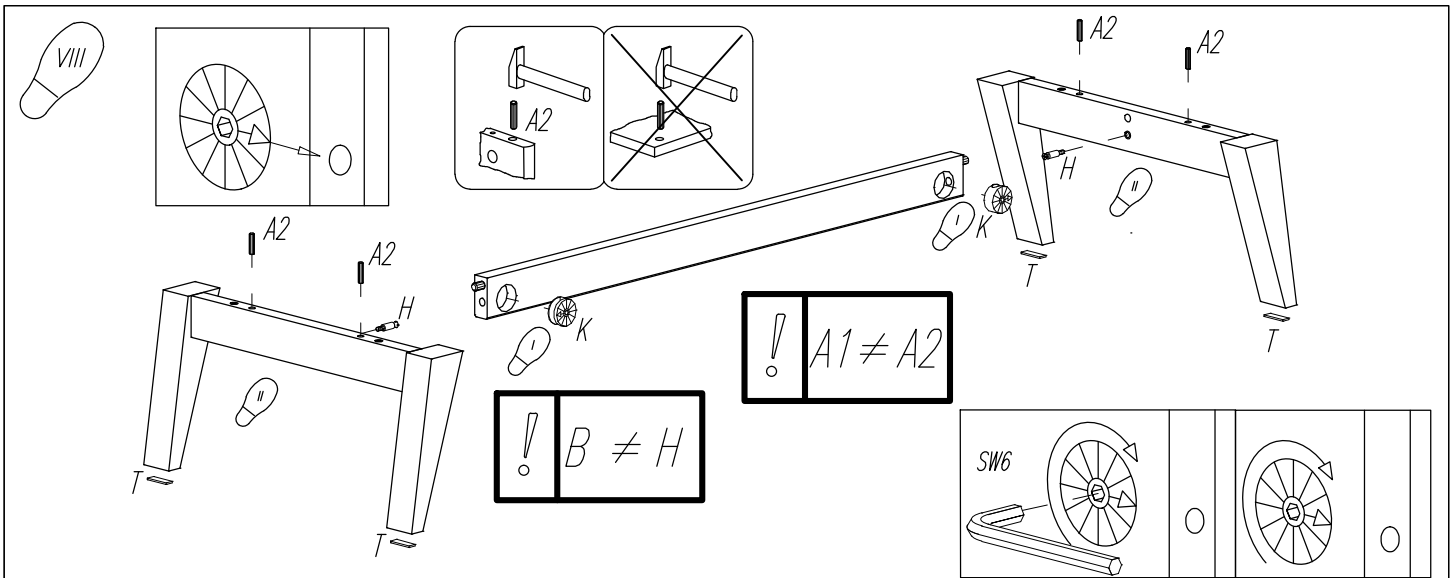

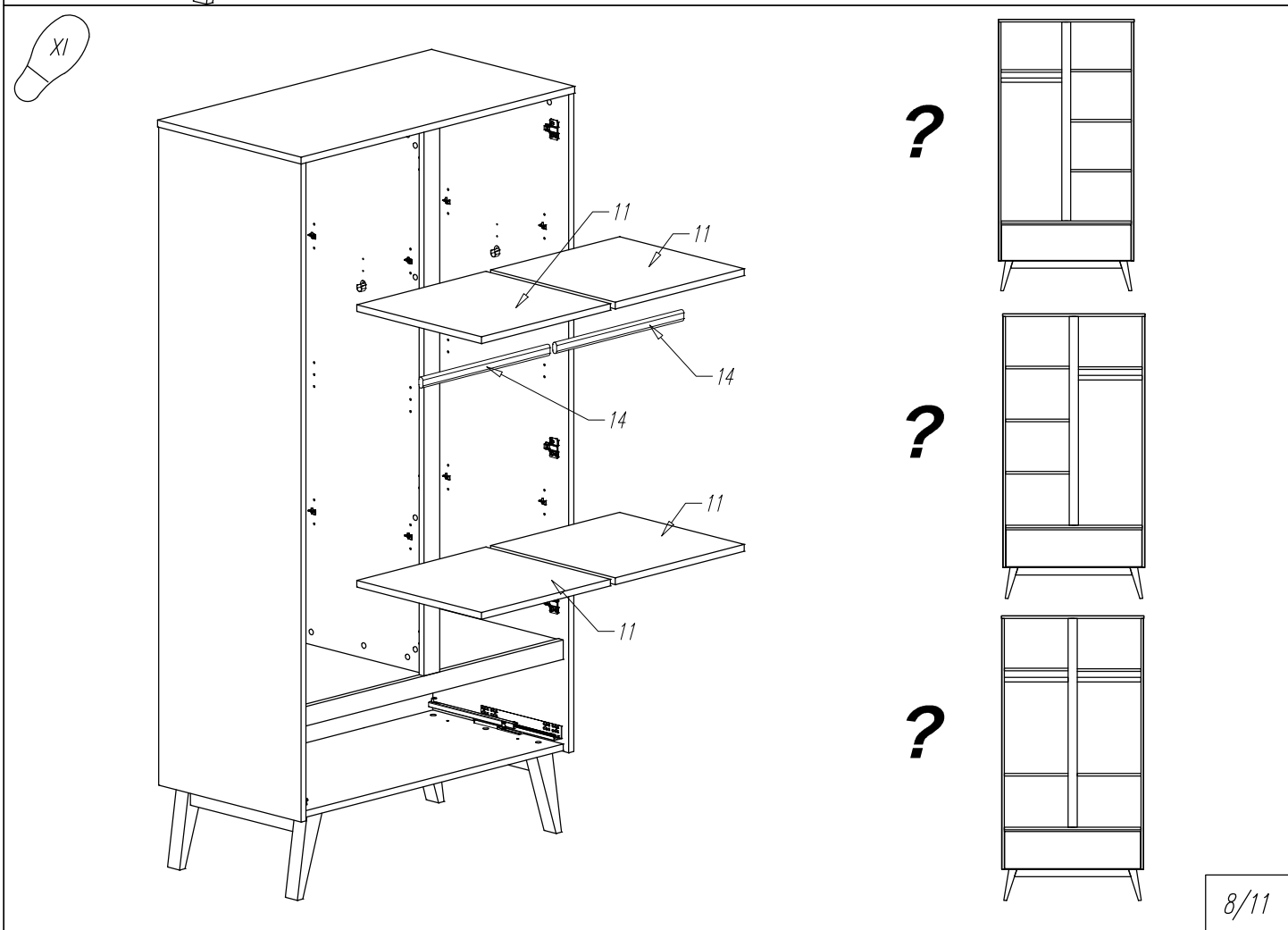
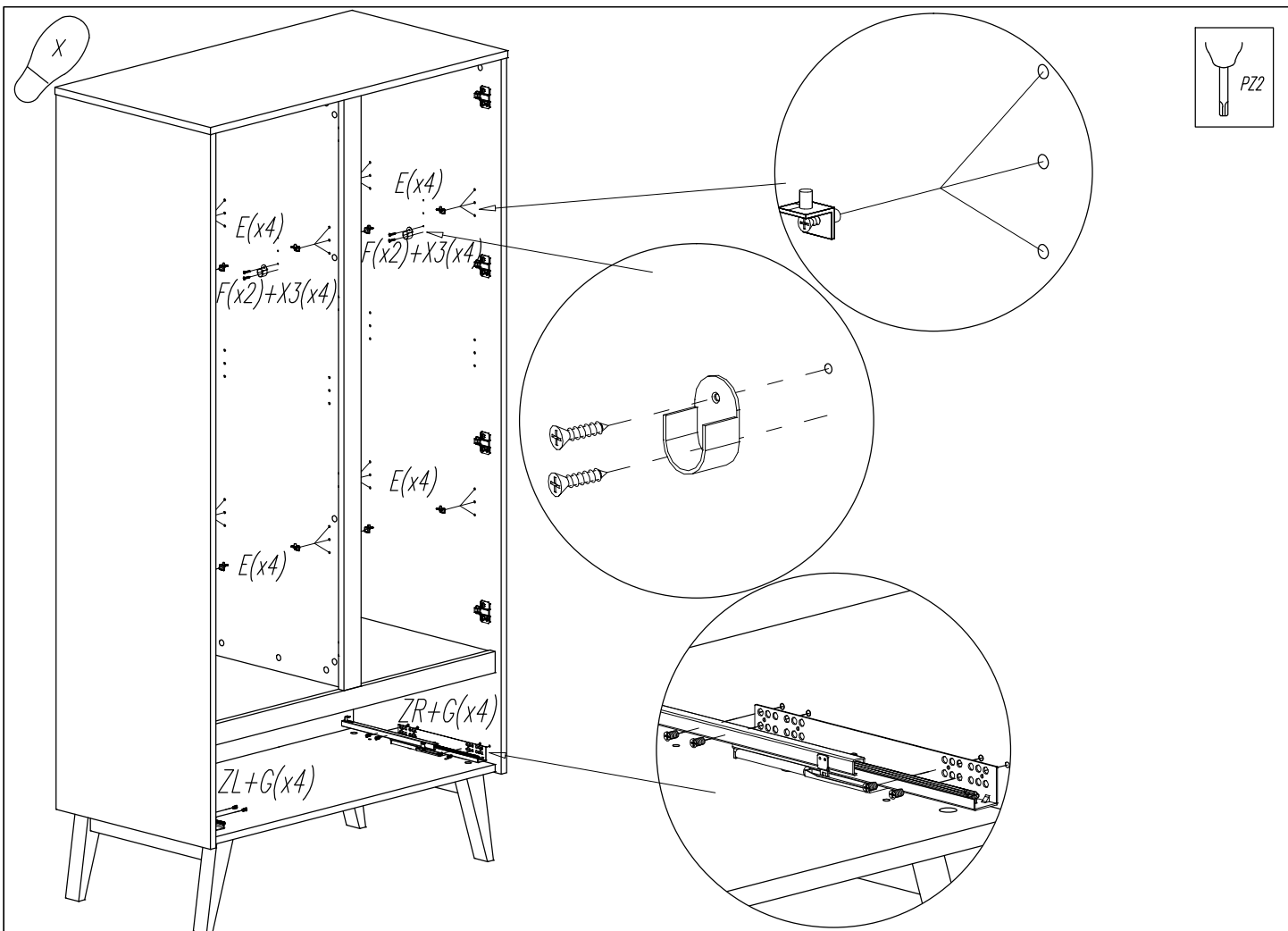

XII

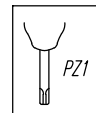
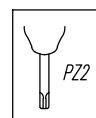
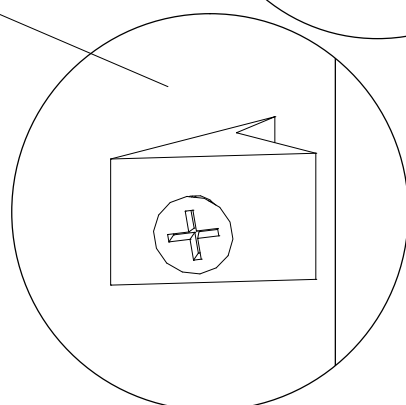
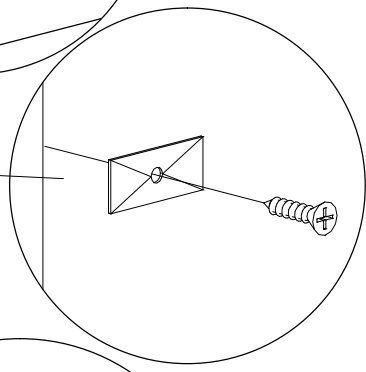
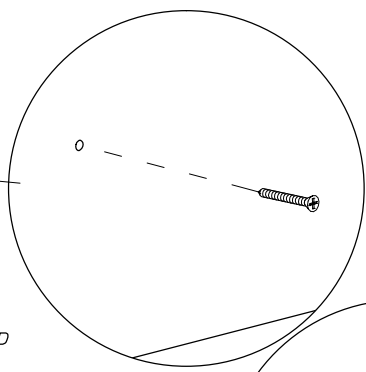
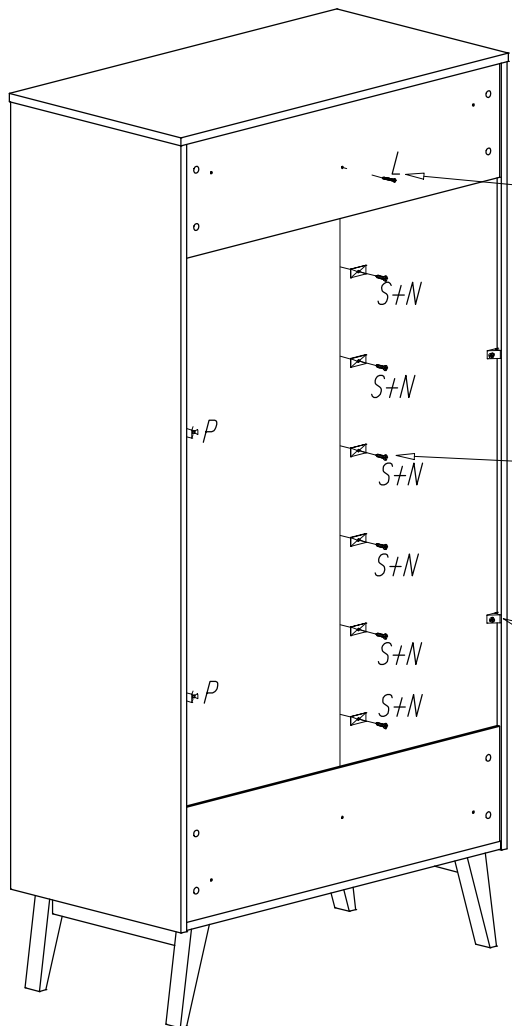

XIII

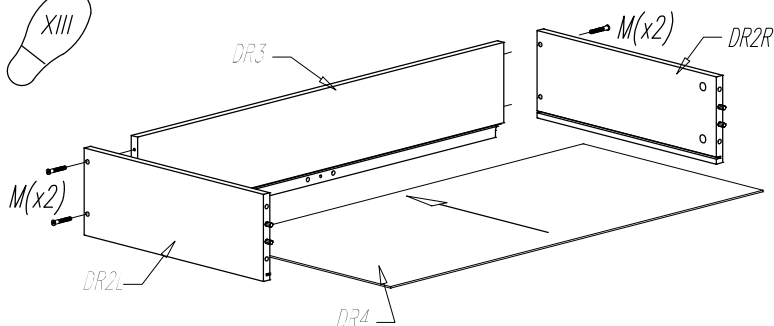

! $D \neq M$

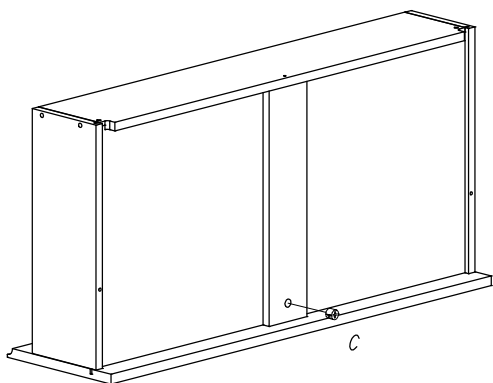
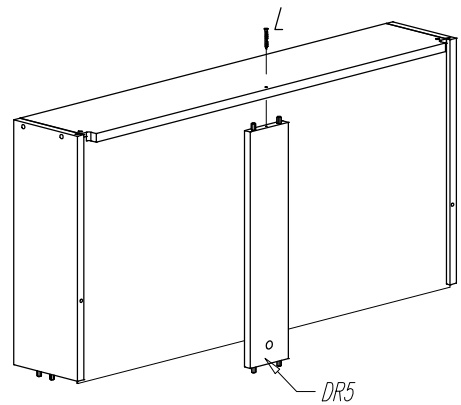
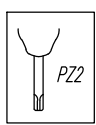
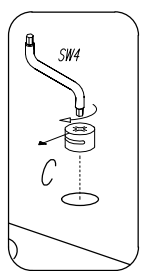
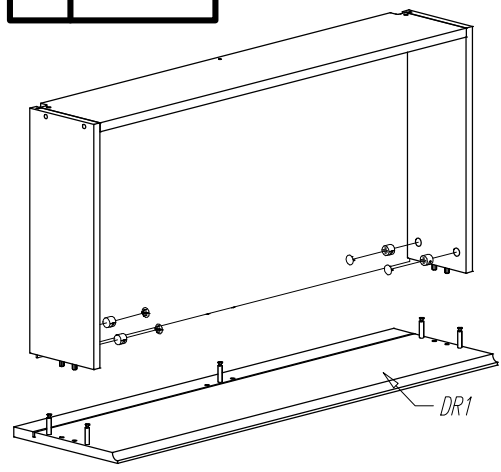

XIV

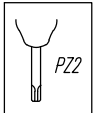
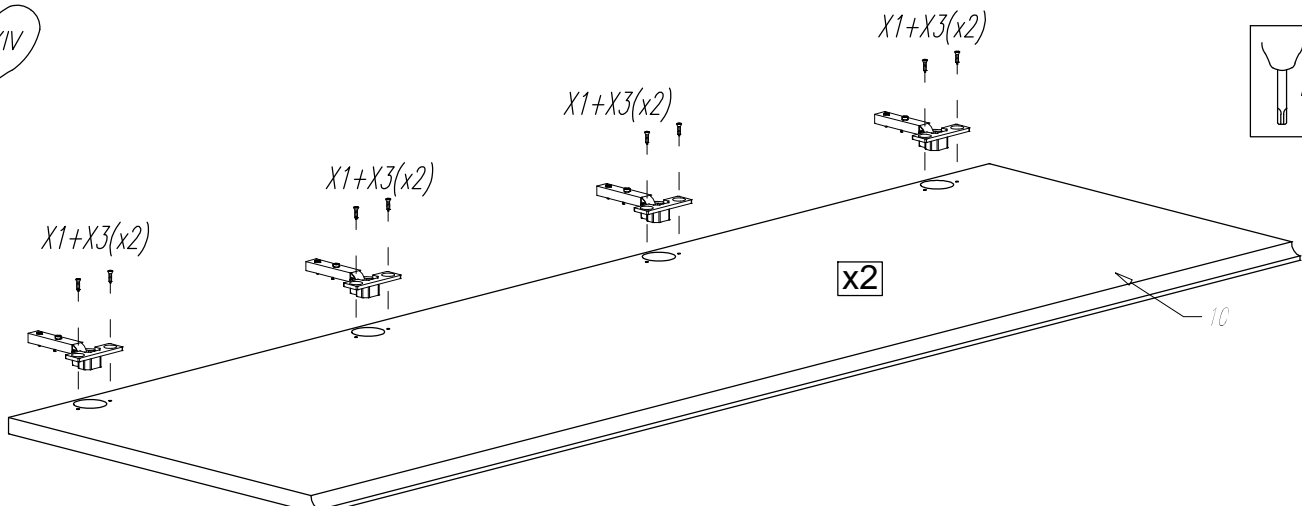

XV

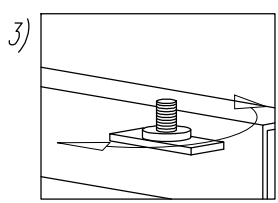
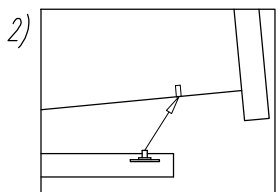
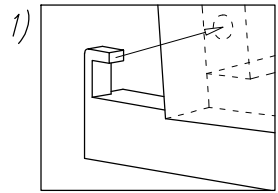
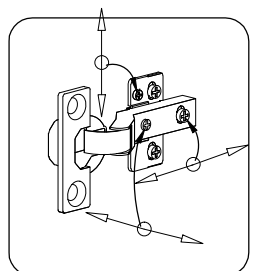
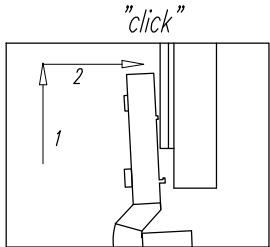
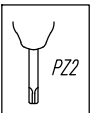
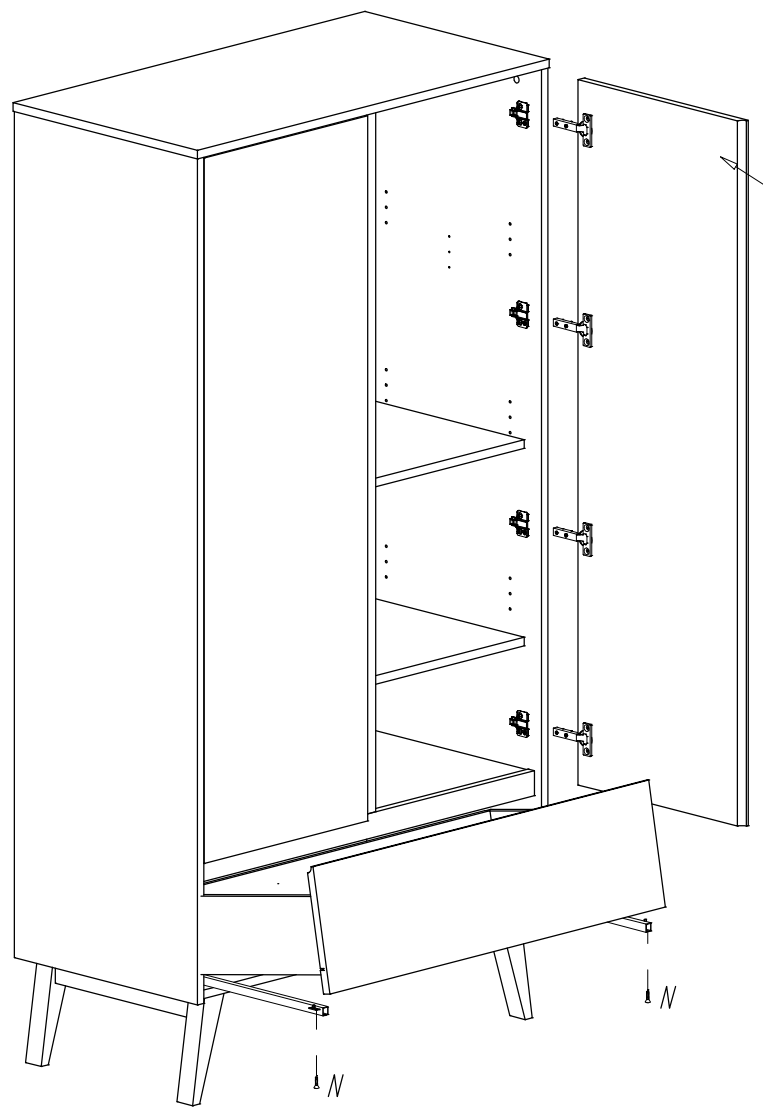



Zabezpieczenie przed przewracaniem

Kippsicherung

Prevention of tipping over

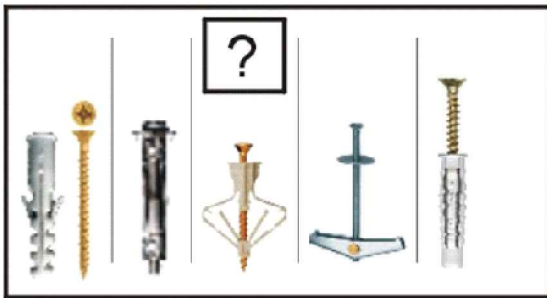
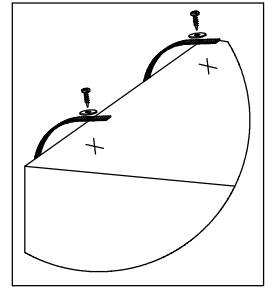
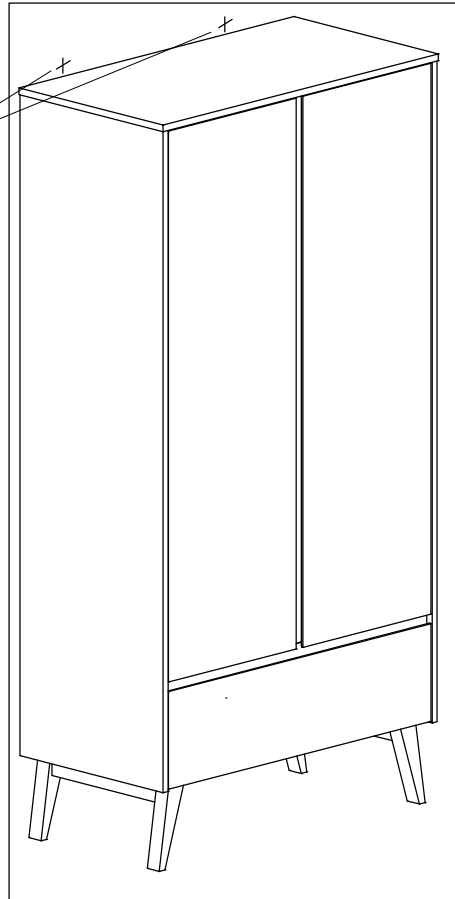
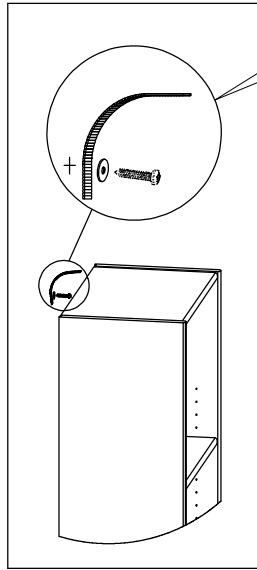
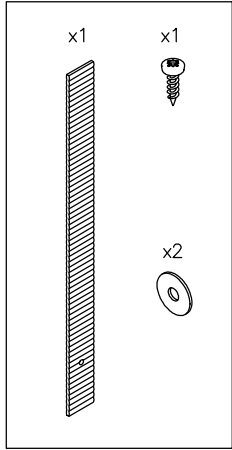
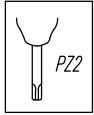

PL
S[] a & ^ A o c [] c e A [A & a] ^ E
U[] a, a e A e i a e A d i ^ * [A ^ \] c e [A & a] A [^ A ^ A] ^ A A e a { A a : \ a e A A [] | ^ A A A } a e y A a A a } ^ A { [&], a e a e } a
, \ i c A A ^ A : ^ \ a e A [i a e A A, ^ c a [a i ^ A a] [, a a] a e \ i c, A [] c e c b a A A [\ a] ^ { A \ } ^ { A } ^ A c & } ^ E

GB
Wall mounting is required.
As wall materials vary, screws for fixing to wall are not included. For advice on suitable screw systems, contact your local specialized dealer.

DE-AT
Wandmontage ist erforderlich.
Österreich: Eisenwarenfachhandel nach geeignetem Befestigungsmaterial erkundigen.

FR
Un montage mural est indispensable.
Sous le nom de la marque, les produits sont vendus par les magasins de bricolage et les magasins de quincaillerie.

SI:
U[] d a) a [] c e a a c } E
S[] A A c } \ a e i a e A e i a e A d i ^ * [A ^ \] c e [A & a] A [^ A ^ A] ^ A A e a { A a : \ a e A A [] | ^ A A A } a e y A a A a } ^ A { [&], a e a e } a
specializiranega prodajalca.

HR:
Potrebna je ugradnja na zid.
Ovaj proizvod se može montirati na zidove od gipsa, betona i opeke. Za savjete o odgovarajućim sustavima za pričvršćivanje na zidove, kontaktirajte lokalnog specijaliziranog trgovca.